

KSTAR

FocusAirTM
Precision Air Conditioner

User Manual

Preface-About the product and manual

[To users]

Dear users! Thank you for purchasing our precision air conditioner! To ensure better use, please read this manual carefully before using it and ensure correct use and operation in order to achieve a lasting and reliable operation effect.

[Warranty]

This product is covered by our maintenance service with the purchase contract or relevant approved procedures.

[Exception clauses]

1. Free warranty period expires;
2. Disassembly or modification of the product without authorization;
3. Violation of product operation or use specifications;
4. Man-made failures;
5. Losses caused by force majeure or other external factors at client site.

[Note: Any of the above exemption clauses will not be covered by the warranty.]

[Customer service]

Shenzhen Kstar Science & Technology Co., Ltd. provides customers with a full range of technical support. You can contact local Kstar office, customer service center or technical department.

[Related description]

1. This manual is provided with the product. Please keep it properly for future reference. If this manual is lost or damaged, please request it directly from the manufacturer;
2. This manual is written for direct expansion air-cooled series products. The content may not be applicable to other models;
3. The copyright of this manual belongs to Shenzhen Kstar Science & Technology Co., Ltd. All rights are reserved. The content is subject to change without notice.

Contents

- Chapter 1 Product Overview 1
 - 1.1 Introduction..... 1
 - 1.2 Model Description 2
 - 1.3 Main Components..... 2
 - 1.4 Environmental Requirements..... 5
- Chapter 2 Mechanical Installation..... 7
 - 2.1 Transportation Inspection 7
 - 2.2 Installation Precautions 8
 - 2.3 System Installation Layout 9
 - 2.4 Installing Indoor Unit 14
 - 2.5 Installing Unit Pipeline..... 20
 - 2.6 Inspection Items for Installation 29
- Chapter 3 Electrical Installation..... 30
 - 3.1 Wiring Content 30
 - 3.2 Indoor Unit Wiring..... 30
 - 3.3 Outdoor Unit Wiring 35
 - 3.4 Installation Check 37
- Chapter 4 Commissioning..... 38
 - 4.1 Electrical Layout..... 38
 - 4.2 Commissioning..... 38
- Chapter 5 Basic Operation 41
 - 5.1 Overview..... 41
 - 5.2 Introduction to the Touch Screen 41
 - 5.3 Touch Screen Navigation..... 42
 - 5.4 Basic Operation..... 43
- Chapter 6 Operation and Maintenance 50
 - 6.1 System Diagnosis and Test 50
 - 6.2 Maintenance of Fan Components..... 51
 - 6.3 Filter maintenance..... 54
 - 6.4 Maintenance of Differential Pressure Switch..... 55
 - 6.5 Maintenance of Condensate Drain Pump (Optional) 55
 - 6.6 Maintenance of Electric Heater (Optional) 56
 - 6.7 Wet Film Humidification Maintenance (Optional) 59
 - 6.8 Maintenance of Electrode Humidifier 60
 - 6.9 Refrigeration System Maintenance 64
- Chapter 7 Troubleshooting..... 68
- Attached Table 1 Maintenance and Inspection Items (Monthly)..... 71
- Attached Table 2 Maintenance and Inspection Items (Semi-annual) 72
- Appendix 1 Identification of Toxic and Hazardous Substances or Elements 73

Chapter 1 Product Overview

FocusAir series precision air conditioners are professional equipment suitable for places that are not easily accessible by the general public.

This chapter introduces the product model, main components, transportation and storage environment requirements of the FocusAir series precision air conditioners.

1.1 Introduction

FocusAir series precision air conditioner is a control system for precision environment. It is suitable for environmental control of small and medium-sized machine rooms, modular machine rooms, data centers using micro-modules, cold/hot aisles, and machine rooms that require energy saving and high heat density.

Integrating the industry's most advanced energy-saving and environmental protection technology and combined with well-designed refrigeration system and powerful and reliable automatic control system, it guarantees the uninterrupted, efficient and reliable operation of key equipment throughout the year.

The cooling capacity range of FocusAir series precision air conditioners: 25~70kW.

The FocusAir series precision air conditioning unit consists of an indoor unit and an outdoor unit. For long connecting pipes, extended components are available; for low-temperature outdoor conditions in winter, cryogenic components are available; for northern areas, fluorine pump energy-saving modules are available.

Cooling capacity characteristics of FocusAir series precision air conditioners:

- (1) Multiple air supply methods, multiple refrigeration types;
- (2) Installation is possible with or without raised floor;
- (3) Suitable for both newly built and reconstructed machine rooms;
- (4) Allow installation in the middle or both sides of the cabinet row;
- (5) Support upper and lower pipe connection and wiring;
- (6) Front and rear maintenance;
- (7) Adapt to the size of mainstream cabinets;
- (8) Unit height is adjustable;
- (9) Advanced smart controller;
- (10) Multiple sets of cabinet temperature sensors;
- (11) DC inverter compressor, automatic speed regulating fan;
- (12) High return air temperature design;

1.2 Model Description

The model description of FocusAir series air conditioner is shown in Table 1-2-1.

Table 1-2-1 Air conditioner model description

1	2	3	4	5	6	7
F	S	0	4	0	F	A
1~7 digits, describing common product configuration						
Naming instructions:						
1~2	digits	-	Product series name			
	FS	-	FocusAir row-level precision air conditioner series			
3~5	digits	-	Total cooling capacity -kW			
	xxx	-	Total cooling capacity: 25kW~70kW			
6	digit	-	Wind out type			
	F	-	Front air supply			
	S	-	Air supply on both sides			
	L	-	Left air supply			
7	R	-	Right air supply			
	digit	-	Refrigeration system configuration			
	A	-	Compressor system, air-cooled			
	W	-	Compressor system, water-cooled			
	C	-	Chilled water			
G	-	Glycol dynamic natural cooling system				
R	-	Air cooling + fluorine pump refrigeration system				

1.3 Main Components

1.3.1 Indoor Unit

The indoor unit of FocusAir series air conditioner consists of the compressor, the evaporator, EC fan, the controller, the expansion valve, the dry filter, the humidifier, the heater, the liquid solenoid valve and other components.

Compressor

It adopts high efficiency and energy saving DC inverter compressor, featuring high reliability, low noise, long life, easy installation, etc.

Evaporator

The fin-and-tube heat exchanger adopts high-efficiency internally threaded copper pipes and aluminum fins coated with hydrophilic layer, and the application of CFD flow field analysis and optimization matching has greatly improved the heat exchange efficiency.

Expansion valve

The electronic expansion valve can improve the control accuracy and response speed, realize accurate cooling and stable system, accurately match the load, and have good energy-saving effect.

Fan

It adopts high-efficiency and high-reliability direct-connected fans, with large air volume, long air supply distance, and easy maintenance.

Dry filter

The dry filter can effectively remove the moisture present in the system within a period of time and also filter the impurities generated in the long-term operation to ensure normal operation of the system.

Liquid circuit solenoid valve

The liquid pipelines on the high and low pressure sides can be shut off during shutdown, which can effectively prevent refrigerant migration during shutdown and reduce the risk of start-up liquid shock of compressor.

Condensate drain pump

Compact structure, large flow and high lift ensure that the unit can overcome the height difference and drain water.

Oil separator

It can improve the oil return efficiency of the system's refrigerating oil, especially suitable for the application scenarios where the indoor and outdoor unit connection pipelines are extremely long.

Sight glass (optional)

The window of the system circulation allows observing the state of the refrigerant and is mainly used to observe the moisture content of the system.

Wet film humidifier (optional)

It adopts a wet film core with strong water absorption, non-toxicity, acid and alkali resistance, mildew resistance, and good flame retardancy, featuring zero power consumption, large humidification capacity, water saving, and easy maintenance.

Electrode humidifier (optional)

Automatic control, energy saving and water saving, automatic drainage, automatic cleaning, and

convenient maintenance.

Heater (optional)

PTC electric heating features compact structure, large heating capacity, uniform heat and little influence on the internal wind resistance of the unit, the electric heating surface is not charged, and the safety is high.

Extension assembly (optional)

When the length of the connecting pipe exceeds 30m, an extension assembly should be added to ensure the normal start-up and operation of the unit and improve the reliability.

Cryogenic components (optional)

When the outdoor environment temperature is lower than -20°C , increase the assembly of cryogenic components to ensure the reliable operation of the unit above -35°C .

Fluorine pump energy saving module (optional)

In northern areas, when the outdoor environment temperature is lower than 5°C in winter, the fluorine pump function is activated, and the outdoor natural cold source is used for cooling, which improves the energy-saving effect.

1.3.2 Outdoor Unit

The outdoor unit of our machine room air conditioner consists of an external fan, condenser, and inverter.

External fan

It adopts high-efficiency and high-reliability axial flow fan with large air volume and easy maintenance.

Condenser

The condenser adopts high-efficiency internally threaded copper pipes and punched-slit fins, which greatly improves the heat exchange efficiency.

Inverter

According to the condensing pressure signal, the inverter makes stepless adjustments to the outdoor fan.

1.3.3 Controller

The microprocessor controller of the FocusAir series air conditioner is equipped with a 4.3-inch (FS012) or 7-inch (FS025~FS070) touch display, with simple user interface. Multi-level password protection can

effectively prevent illegal operations. The controller has functions such as power-down self-recovery and fault alarm reminder. Through the menu operation, you can accurately understand the running time of each main component. The expert fault diagnosis system can automatically display the current fault content, which is convenient for the personnel to perform equipment maintenance. It is equipped with external interfaces such as RS485 interface and USB supporting safety protection mechanism. The communication protocol adopts the standard communication protocol of the Ministry of Information Industry. The panel of the microprocessor controller is shown in Fig. 1-3-1.

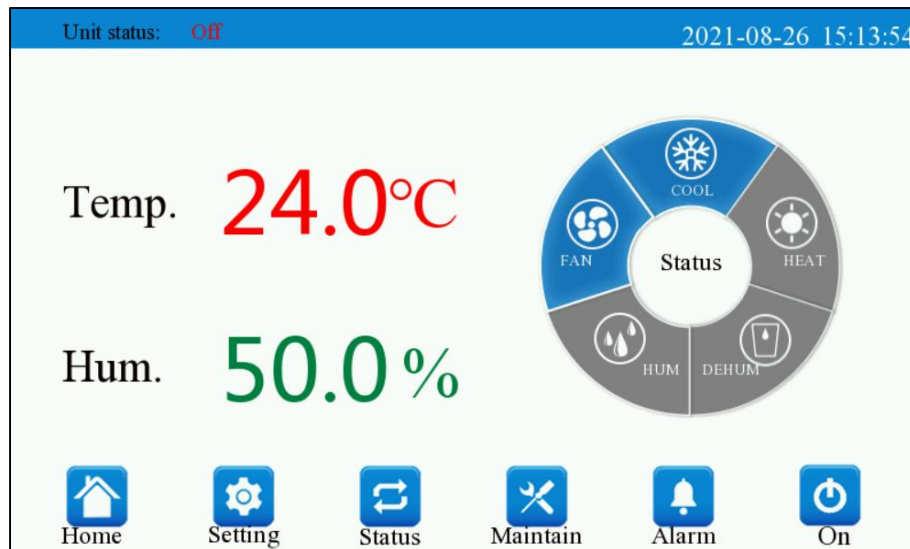

Fig. 1-3-1 Micro-processing controller panel

1.3.4 Remote monitoring software

FocusAir series air conditioners adopt the standard agreement of the Ministry of Information Industry.

Front-end smart device protocol. Through the equipped RS485 interface, the FocusAir series air-conditioner system can communicate with the background computer and accept the control of the background software.

1.4 Environmental Requirements

1.4.1 Operating

The operating environment of FocusAir series air conditioners should meet the requirements of GB4798.3-2007. See Table 1-4-1 for details.

Table 1-4-1 Operating environment requirements

Item	Requirements
Ambient temperature	Indoor: 18°C~45°C, 20%RH~85%RH Outdoor: -20°C~+45°C (normal type) -35°C~+45°C (cryogenic type)
Protection (outdoor unit)	IP54

Item	Requirements
Altitude	<1000m, please consult our technicians when exceed 1000m
Operating voltage range	380V±10%, 50/60±2Hz
Inlet water requirements for humidification	Inlet water quality: Clean tap water; Inlet water temperature: 4~40°C; Inlet water pressure: 0.1~0.7Mpa. [Note: The electrode humidifier cannot use deionized water or distilled water. Conductivity: 350~750µs/cm]

1.4.2 Storage

The storage environment of in-row air conditioners should meet the requirements of GB4798.1-2019. See Table 1-4-2 for details.

Table 1-4-2 Storage environment requirements

Item	Requirements
Storage environment	Indoor, clean (no dust, etc.)
Ambient humidity	5%RH~95%RH (non-condensing)
Ambient temperature	-40°C~+70°C
Storage time	The total transportation and storage time should not exceed 6 months. The performance needs to be re-calibrated after 6 months

Chapter 2 Mechanical Installation

This chapter introduces the mechanical installation of FocusAir series air conditioners, including transportation, unpacking, installation layout, and installation steps.

2.1 Transportation Inspection

2.1.1 Transportation and handling

When transporting, try to choose railway and shipping. When choosing automobile transportation, you should choose roads with better road conditions to prevent excessive bumps.

The weight parameters of air-conditioner are shown in Table 2-3-1. For unloading and transportation, try to use mechanical handling tools such as hydraulic forklifts and electric forklifts to transport the equipment to the place closest to the installation site. When unloading and transporting with a forklift, please fork in the direction as shown in Fig. 2-1-1, and try to place the fork at the center of gravity to prevent tipping.

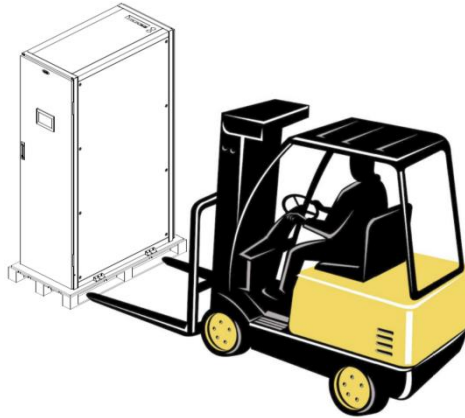

Fig. 2-1-1 Fork in and transport

During transportation, the inclination angle of the indoor unit should be kept within $\pm 15^\circ$, as shown in Fig. 2-1-2.

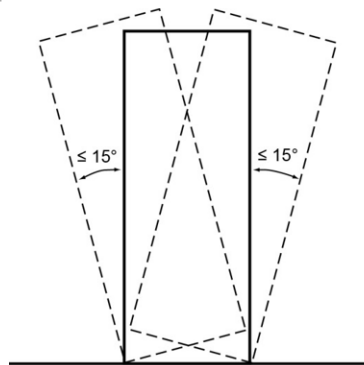

Fig. 2-1-2 Inclination of handling

Note

1. Please wear protective gloves when transporting to avoid scratching your hands.
2. Be prepared for load-bearing during transportation to avoid being crushed or sprained by heavy objects.

3. When pulling out the equipment from the cabinet, be careful of the unstable or heavy equipment installed on the cabinet to avoid being crushed or injured.

2.1.2 Unpacking

Try to move the equipment to the place as close as possible to its final installation site before unpacking it.

Unpacking steps:

1. Remove packaging materials

The unit is packaged in high-strength environmentally friendly paper. Remove the paper packaging, wrapping film and protective materials in sequence on site.

2. Remove bottom tray

The unit is fixed on the bottom tray of the package with M8 bolts, which can be disassembled with a solid wrench, ratchet wrench or socket wrench.

2.1.3 Inspection

When receiving the FocusAir series air conditioner, check whether the accessories are complete according to the packing list, and check whether any part has obvious damage. If any part is missing or damaged, report to the carrier immediately. If you find any concealed damage, also report it to the carrier and the local office of the supplier.

2.2 Installation Precautions

Correct installation is essential in order to achieve the design performance of the equipment and maximize its service life. The content of this section should be applied in conjunction with the current mechanical and electrical installation regulations.

FocusAir series air conditioner adopts split floor installation. The indoor unit must be installed on the floor of the equipment room or computer room, while the outdoor unit can be installed on the floor of the outdoor or other rooms.

Before installing the equipment, confirm whether the installation environment meets the requirements (see *1.4 Environmental Requirements*), and confirm whether the building needs to be modified to match the construction of pipe laying, wiring and ventilation ducts.

The installation must strictly follow the design drawings and reserve space for maintenance. Refer to the engineering dimension drawings provided by the manufacturer.

2.3 System Installation Layout

2.3.1 System schematic diagram

For FocusAir series precision air conditioners, refer to Fig. 2-3-1 and Fig. 2-3-2 for the system schematic diagram. The diagrams are for reference only.

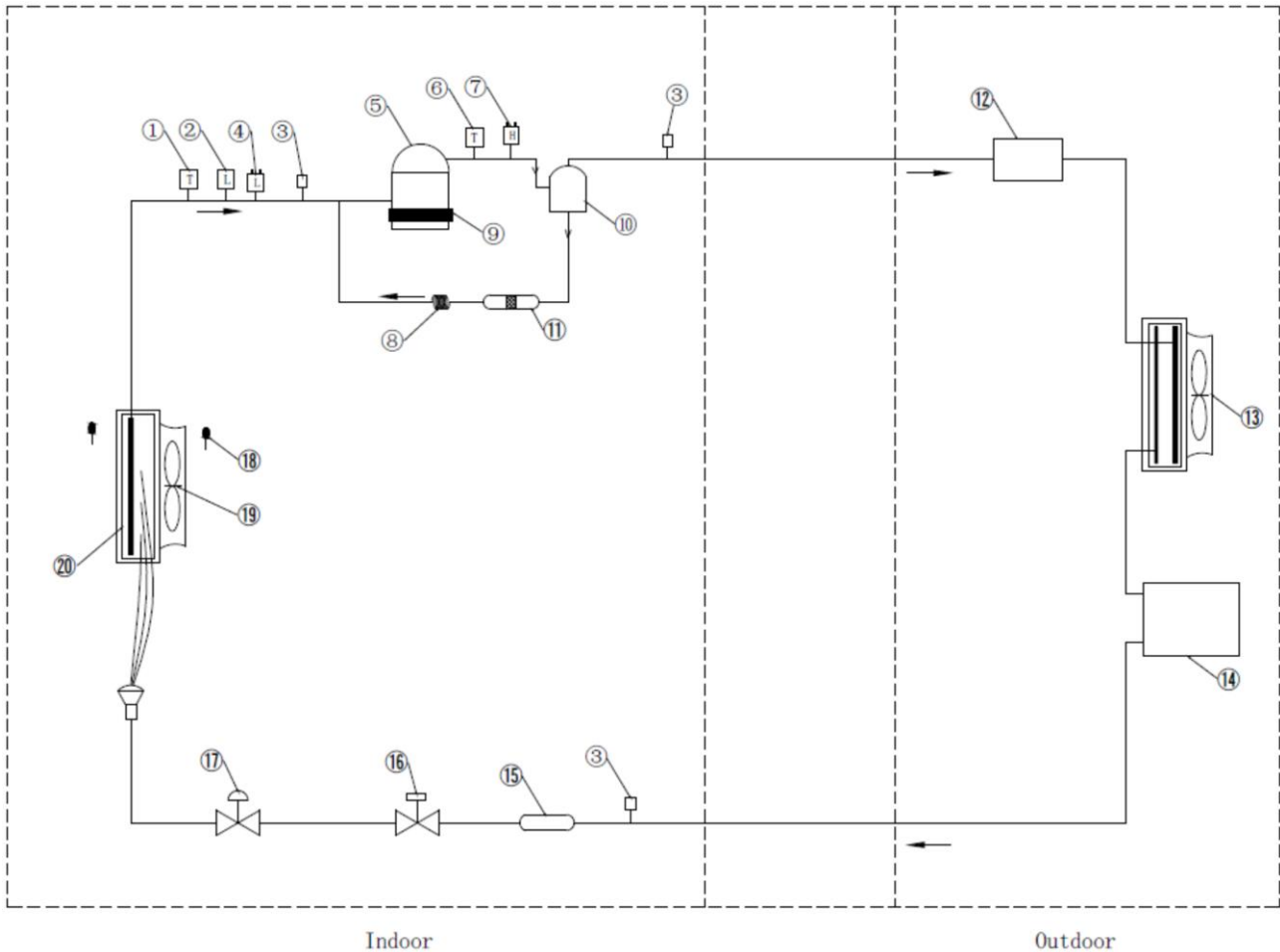

Item	Description	Item	Description
①	Suction temperature	⑪	Oil filter
②	Suction pressure	⑫	Extension assembly
③	Needle valve	⑬	Outdoor unit
④	Low pressure switch	⑭	Cryogenic components
⑤	Compressor	⑮	Dry filter
⑥	Exhaust temperature	⑯	Solenoid valve
⑦	High pressure switch	⑰	Electronic expansion valve
⑧	Oil return capillary	⑱	Temperature and humidity sensor
⑨	Electric heating belt	⑲	Indoor fan
⑩	Oil separator	⑳	Evaporator

Fig. 2-3-1 Schematic diagram of FocusAir air conditioning system (non-fluorine pump type)

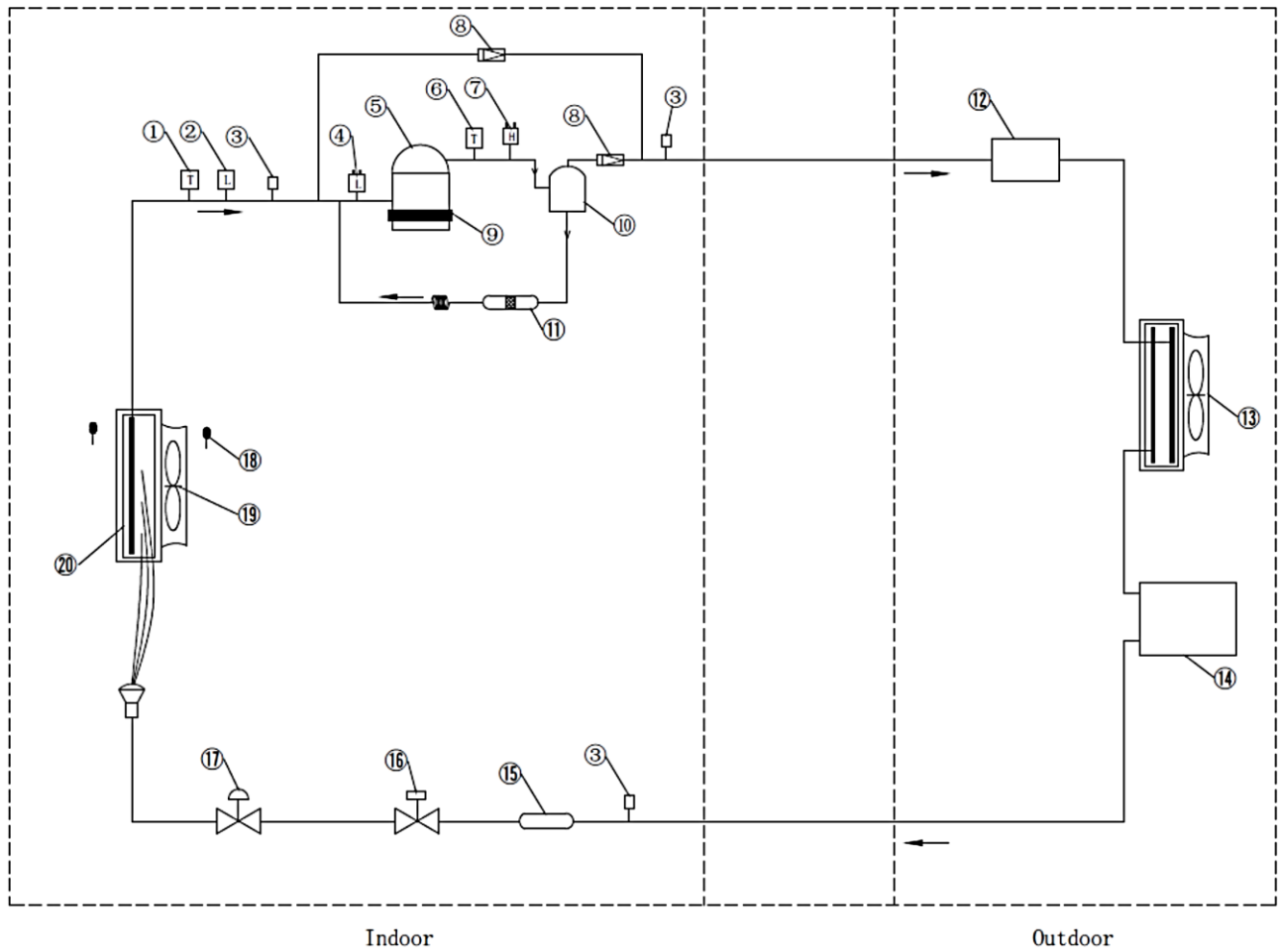

Item	Description	Item	Description
①	Suction temperature	⑪	Oil filter
②	Suction pressure	⑫	Extension assembly
③	Needle valve	⑬	Outdoor unit
④	Low pressure switch	⑭	Energy-saving module
⑤	Compressor	⑮	Dry filter
⑥	Exhaust temperature	⑯	Solenoid valve
⑦	High pressure switch	⑰	Electronic expansion valve
⑧	Check valve	⑱	Temperature and humidity sensor
⑨	Electric heating belt	⑲	Indoor fan
⑩	Oil separator	⑳	Evaporator

Fig. 2-3-2 Schematic diagram of FocusAir air conditioning system (fluorine pump type)

2.3.2 System installation diagram

The installation method of the unit is shown in Fig. 2-3-3 and Fig. 2-3-4.

⚠ Note

When the condenser is installed higher than the compressor, it is necessary to install reverse U-shaped bend or

Model	Dimensions (W×D×H) (mm)	Net weight (kg)
FS070 series	600×1100/1200×2000/2200	≤375

Remarks: The parameters in this table are only the basic size of the product. The specific size of the product can be adjusted according to the needs of projects.

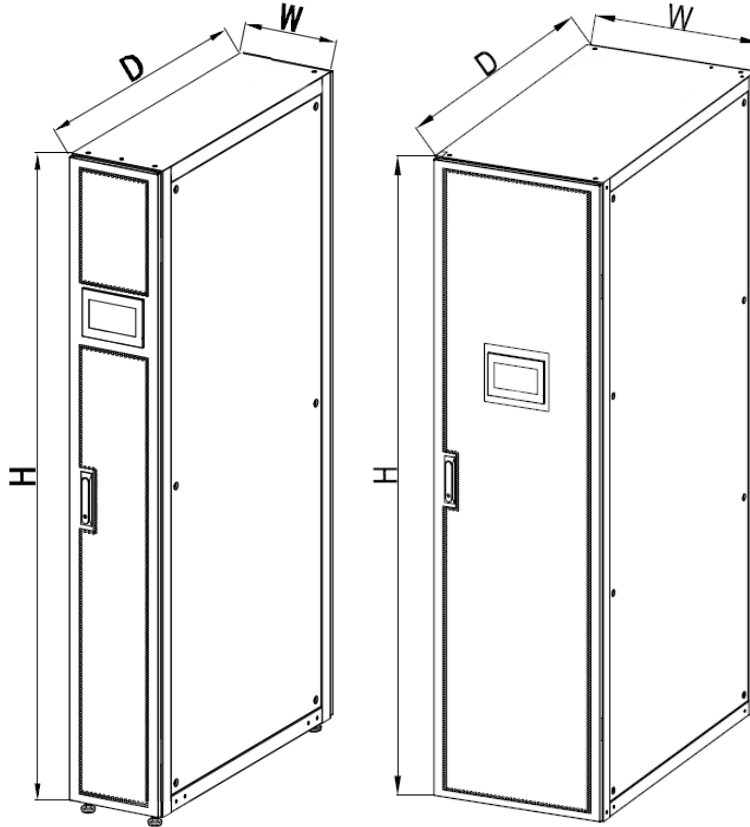

Fig. 2-3-5 Dimensional drawing of indoor unit

(2) Energy saving module

Table 2-3-2 Energy-saving module dimensions (unit: mm)

Model	Size					Net weight (kg)
	D	W	H	D1	D2	
ESM022	606	400	1030	270	662	≤124

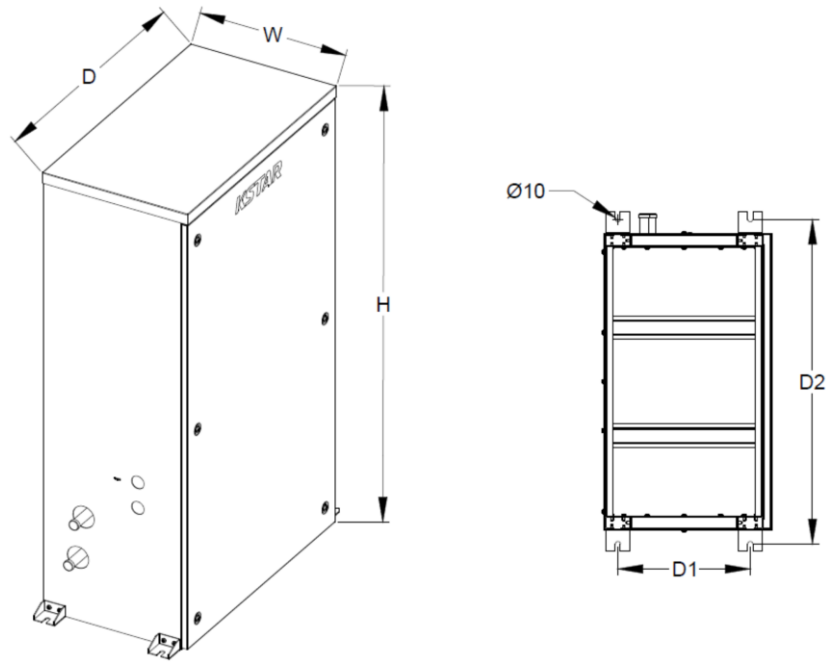

Fig. 2-3-6 Dimensional drawing of energy-saving module

2.4 Installing Indoor Unit

2.4.1 Machine room requirements

The machine room requirements are as follows:

1. Moisture-proof and heat preservation work should be done in order to ensure the normal operation of the environmental control system in the air-conditioned room;
2. The machine room must have good heat insulation and a closed moisture-proof layer; the moisture-proof layer of the ceiling and walls must be made of polyethylene film; the paint on the concrete wall and floor must be moisture-proof;
3. The entry of outdoor air may increase the load of heating, cooling, humidification, and dehumidification of the system. Therefore, it is necessary to minimize the entry of outdoor air into the machine room. It is recommended that the intake of outdoor air be kept below 5% of the entire indoor air circulation;
4. All doors and windows should be fully enclosed, and the gap should be as small as possible.

2.4.2 Installation space

In-row machine room air conditioners are arranged in the rack arrangement and installed side by side with the server cabinets. The air is supplied from the cold aisle and then returned from the hot aisle, which solves the problem of short-circuit of hot and cold airflows, ensures uniform temperature of the server cabinets, eliminates local hot spots, thereby increasing the operating reliability of the server and effectively reducing unnecessary energy consumption.

2.4.3 Maintenance space requirements

To facilitate maintenance operations, leave a 900mm area in the front or back of the equipment. In this way, all required regular maintenance can be performed from the front or back. To ensure that the equipment can be moved out of the rack for maintenance, an open area of at least $D+100$ mm must be reserved on the opposite side of the maintenance area.

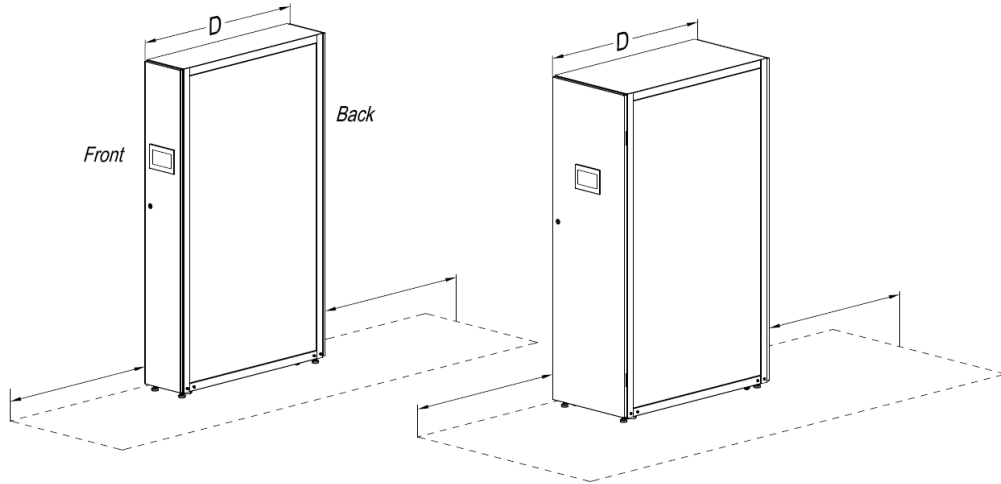

Fig. 2-4-1 Equipment maintenance air conditioner

2.4.4 Installation steps

(1) Unit fixing holes

Both the bottom and the top of the air conditioning unit are provided with fixing holes. The bottom hole can be bolted to the floor bracket of the machine room, and the top hole can be bolted to the top bracket. Fig. 2-4-2 and Fig. 2-4-5 show the distribution of fixed threaded holes for FocusAir series units. There are four $\phi 13.5$ bolt fixing holes at the bottom of the unit, which can be fixed with bolts and floor brackets.

Table 2-4-1 Size of unit fixing hole (unit: mm)

Applicable models		FS012	FS025/30		FS025/30/40/50/60/70	
Air-conditioner cabinet	Width (mm)	300	300		600	
	Depth (mm)	1400	1100	1200	1100	1200
Size code	L1 (mm)	1325	1025	1125	1025	1125
	L2 (mm)	200	200	200	300	300
	L3 (mm)	1310	1010	1110	1010	1110
	L4 (mm)	160	160	160	400	400
	K1 (mm)	37.5	37.5	37.5	37.5	37.5
	K2 (mm)	50	50	50	150	150
	K3 (mm)	45	45	45	45	45
	K4 (mm)	70	70	70	100	100

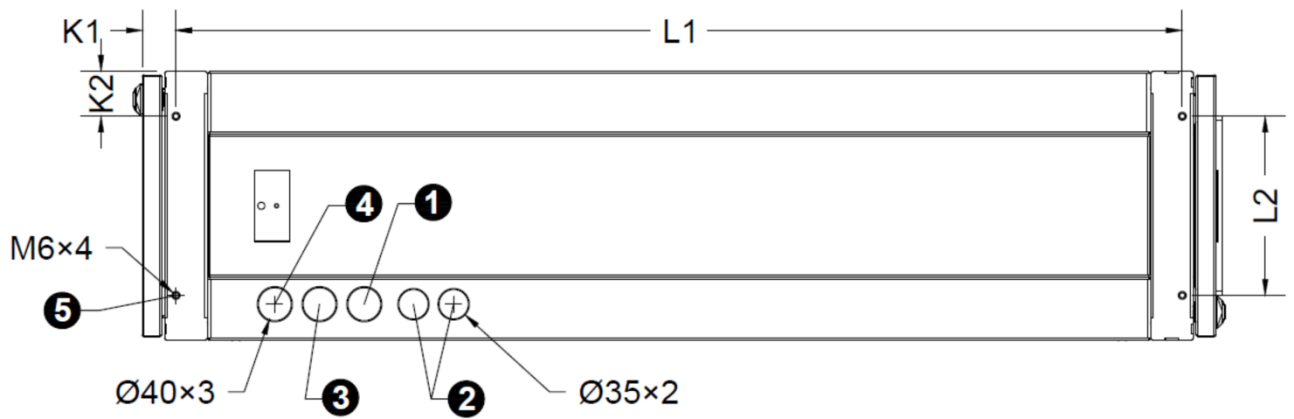

Fig. 2-4-2a Top view of 300mm wide model

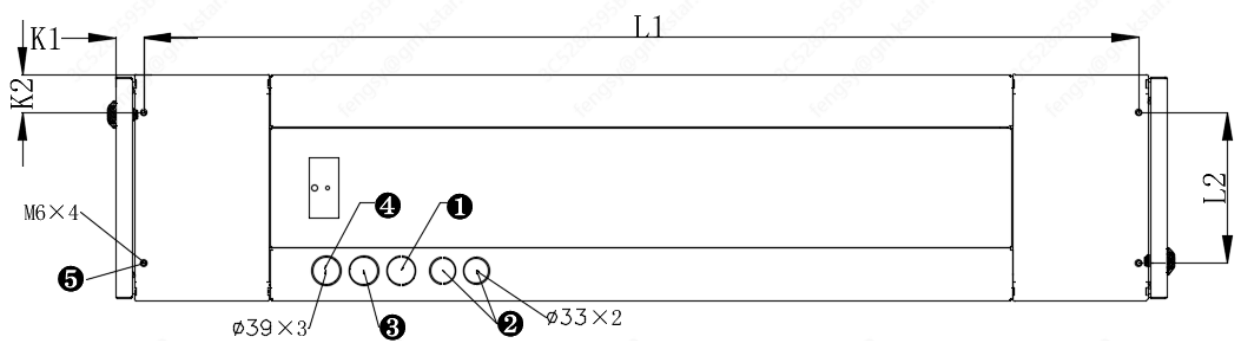

Fig. 2-4-2b Top view of FS012 wide model

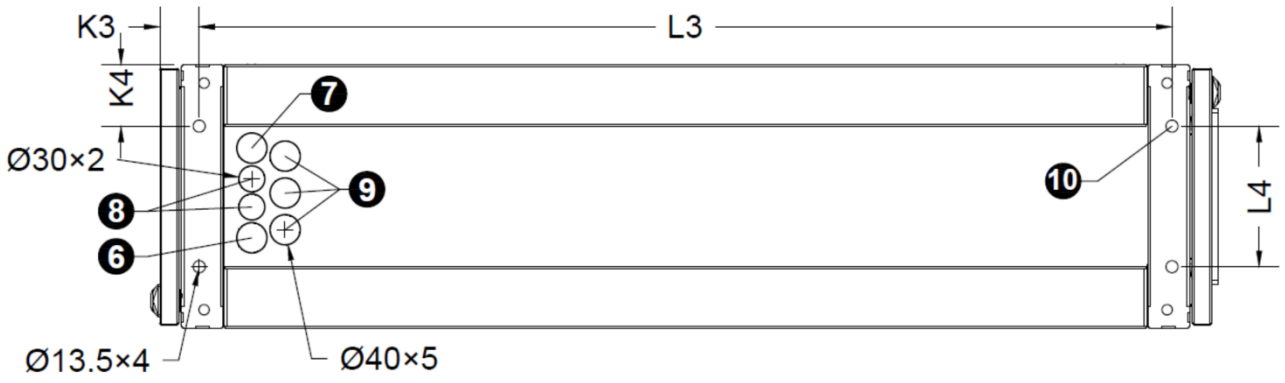

Fig. 2-4-3a Bottom view of 300mm wide model

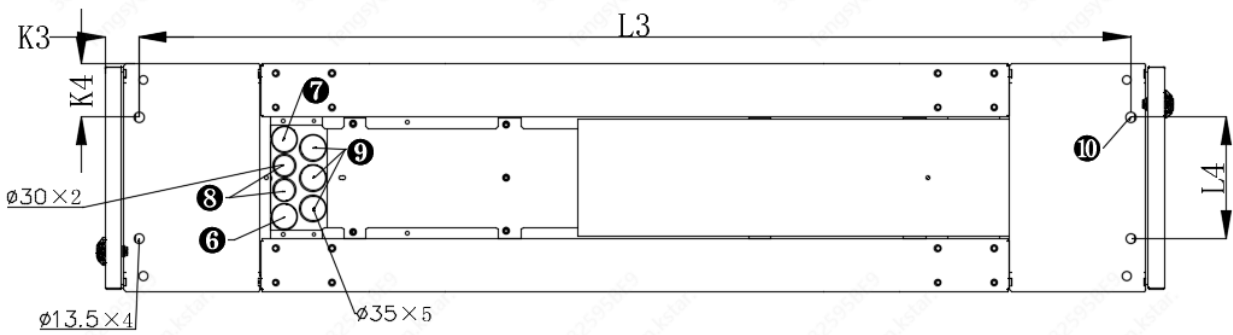

Fig. 2-4-3b Bottom view of FS012 wide model

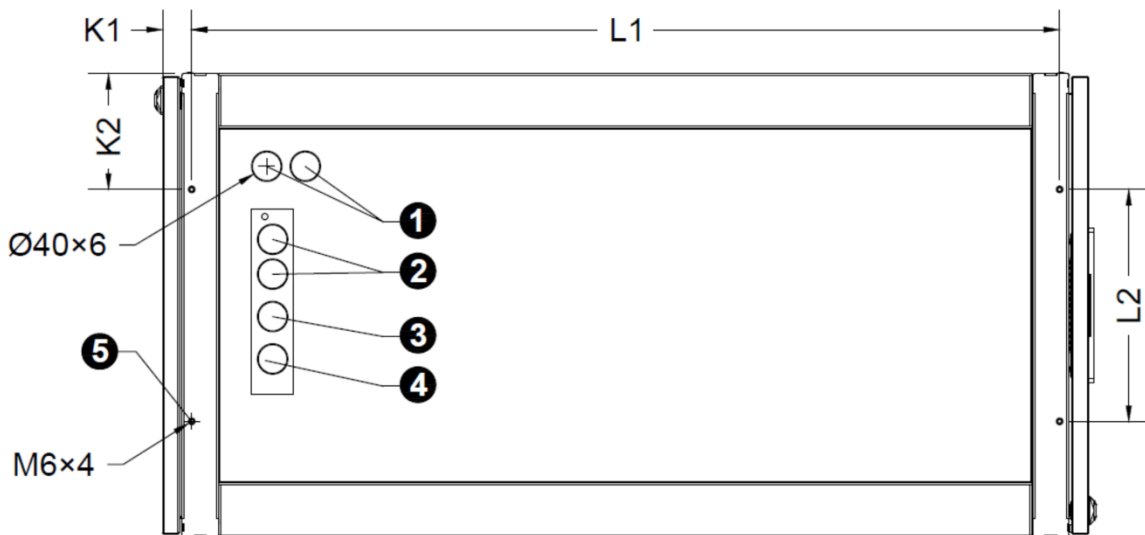

Fig. 2-4-4 Top view of 600mm wide model

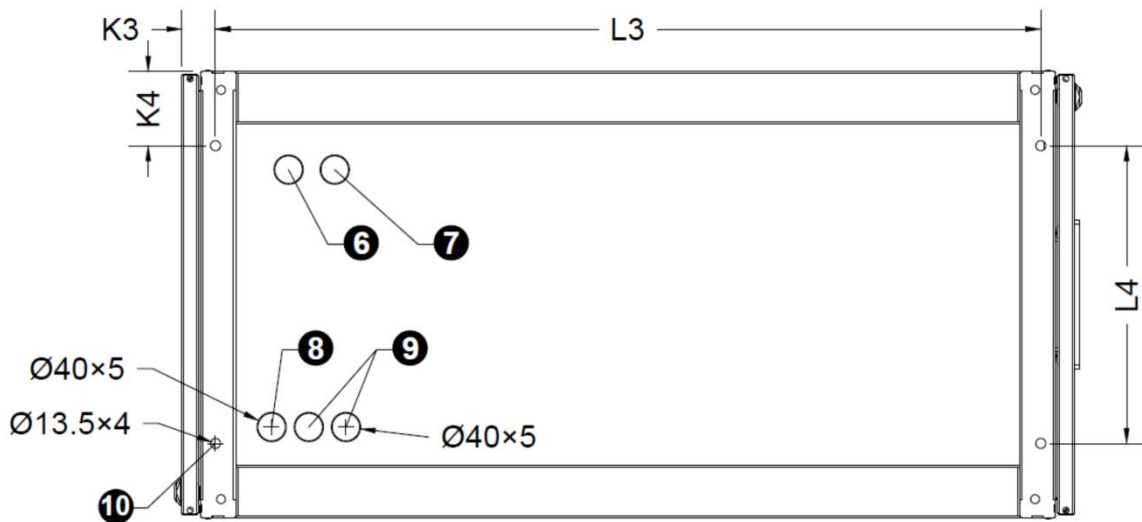

Fig. 2-4-5 Bottom view of 600mm wide model

Item	Description	Item	Description
①	Top cable hole	②	Top water inlet/drain hole
③	Top refrigerant liquid pipe hole	④	Top refrigerant gas pipe hole
⑤	Top pressure riveting bolt fixing	⑥	Bottom refrigerant liquid pipe hole
⑦	Bottom refrigerant gas pipe hole	⑧	Bottom cable hole
⑨	Bottom water inlet/drain hole	⑩	Base fixing bolt hole

When the air conditioner base needs to be installed on site, a shock-absorbing strip (EPDM rubber, thickness $\geq 5\text{mm}$) should be added between the ground and the base; the minimum height of the base is $\geq 200\text{mm}$.

(2) Leveling unit (if leveling feet is equipped)

Anchor bolt adjustment method: adjust the anchor bolt clockwise to increase the unit height and counterclockwise to lower it. The adjustment range of the anchor bolt: $0\text{mm}\sim 80\text{mm}$.

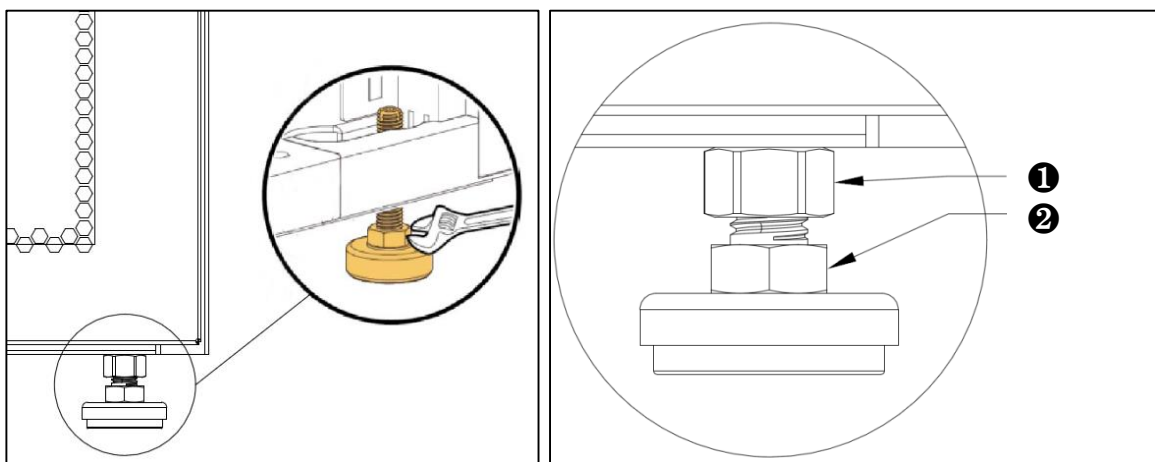

Item	Description
①	Height fixing nut
②	Height adjustment nut

Fig. 2-4-6 Adjusting foot height

(3) Fixing unit

Open the rear door of the unit, remove the filter, remove the bottom filter support to expose the fixing hole of the base, fix the unit as shown in Fig. 2-4-8 with M10 bolts, and then reinstall the filter support.

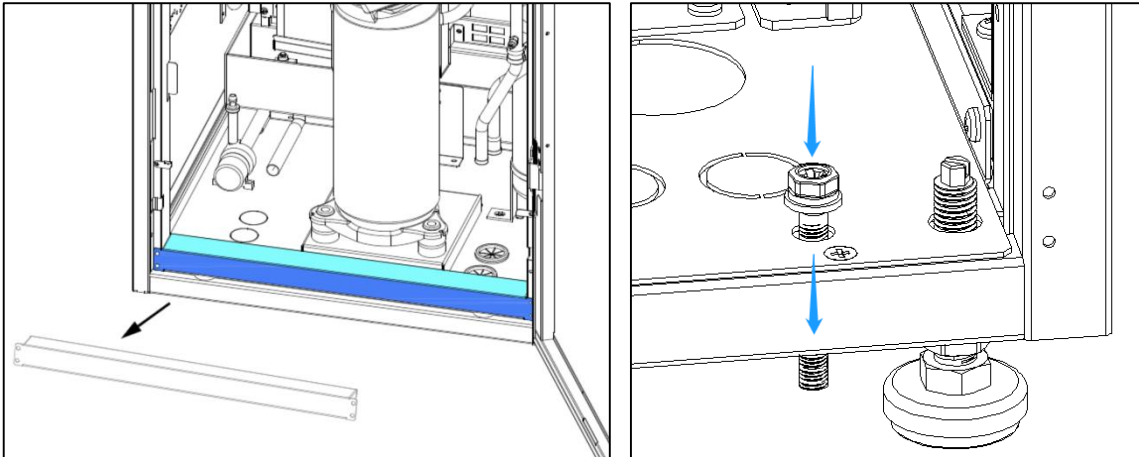

Fig. 2-4-7 Removing filter support

Fig. 2-4-8 Installation of unit fixing bolts

(4) Nitrogen discharge

Before leaving the factory, the unit is filled with 2~3Bar of nitrogen to maintain the pressure. The nitrogen must be discharged on site. Please remove the valve caps on the exhaust pipe, suction pipe and needle valve of the liquid pipe, and connect the pressure gauge hose to the needle valve to discharge the nitrogen.

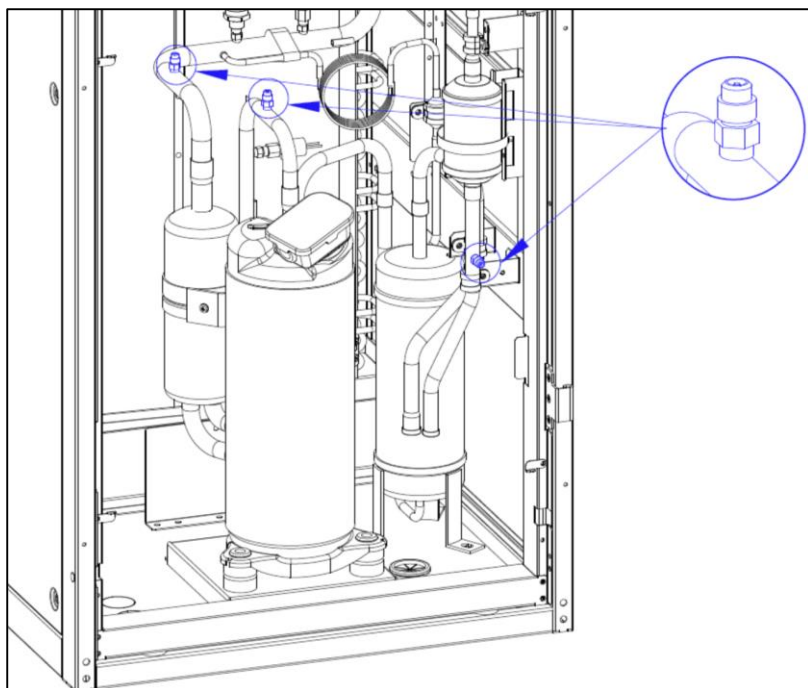

Fig. 2-4-9 Nitrogen discharge

2.5 Installing Unit Pipeline

2.5.1 Content of pipeline connection

1. Connecting copper pipe between the indoor unit and outdoor unit;
2. Condensate drain pipe;
3. Humidification water supply pipe (model with humidification);

2.5.2 Physical interfaces

Table 2-5-1 Physical interfaces of indoor unit of air conditioner

Name	Specifications of reserved interface			
	FS012, 300mm wide	FS025/030, 300mm wide	FS025/FS040/050/060/070, 600mm wide	FS060/070, 600mm wide
Refrigerant liquid pipe	3/4 inch	15.88mm	15.88mm	19.05mm
Refrigerant gas pipe	7/8 inch	19.05mm	19.05mm	22.00mm
Humidification inlet pipe	G3/4 inch external thread			
Gravity drain pipe	ID15*OD22mm			
Water pump drain pipe	ID10*OD16mm			

Table 2-5-2 Physical interfaces of outdoor unit of air conditioner

Name	Specifications of reserved interface			
	KCS018	KCS032/036/042	KCS048/054/062/72	KCS084/096
Refrigerant liquid pipe	5/8 inch	15.88mm	15.88mm	19.05mm
Refrigerant gas pipe	3/4 inch	19.05mm	22.22mm	25.4mm

Table 2-5-3 Physical interfaces of cryogenic components

Name	Specifications of reserved interface	
	DW-07	DW-14
Refrigerant liquid pipe	7/8-14UNF stop valve (5/8')	19.05mm (welded)

Table 2-5-4 Physical interface of energy-saving module

Name	Specifications of reserved interface
Refrigerant liquid pipe	19.05mm

2.5.3 Preparation of installation materials

1. It is recommended to use R410a refrigerant from DuPont, Daikin, Honeywell and other manufacturers of equivalent quality;
2. The oil trap is made according to the on-site pipeline specifications and the recommended dimensions in Table 2-5-5;

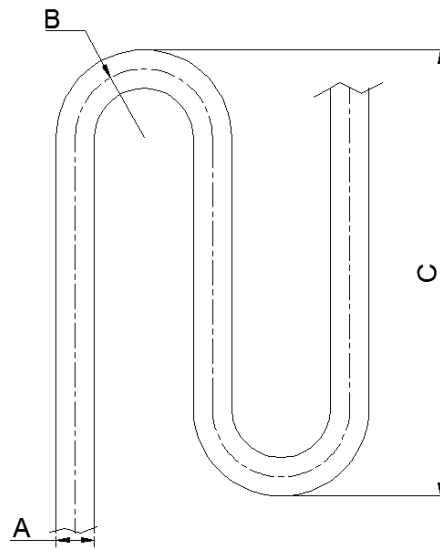

Fig. 2-5-1 Oil trap

Table 2-5-5 Recommended size of oil trap

A		B	C
mm	inch	mm	mm
φ19.05	3/4	≥34	≤150
φ22	7/8	≥36	≤150
φ25.4	1/1	≥45	≤150
φ28	1-1/8	≥50	≤150

3. Copper pipes and thermal insulation cotton;

Table 2-5-6 Recommended size of pipeline and insulation cotton (unit: mm)

Model	FS series	
	Gas pipe (outer diameter × wall thickness)	Liquid pipe (outer diameter × wall thickness)
10m	22.0×1.5	15.88×1.2
20m	22.0×1.5	15.88×1.2
30m	22.0×1.5	15.88×1.2
40m*	22.0×1.5	15.88×1.2
50m*	25.4×1.5	19.05×1.2

Model	FS series	
60m*	25.4×1.5	19.05×1.2
Thermal insulation cotton	Thickness≥9	
Note: * indicates the need to add pipeline extension assembly; the pressure bearing of the copper pipe is above 4.5MPa.		

4. Humidification water supply pipe;

When the unit is equipped with wet film humidification, a silicone hose with an inner diameter of 12mm needs to be connected externally and tightened with a hose clamp;

5. Drain pipe;

1) A section of natural drain pipe is equipped inside the unit. The specification is ID15*OD22, and the pipe can be extended on site according to this hose specification;

2) The unit is equipped with a strong drain pump and a 3m long silicone hose drain pipe with a specification of ID10*OD16, which can be extended on site according to this hose specification; the drainage height of the pump should not exceed 5m from the cabinet installation floor.

6. Pipeline support;

The support of the refrigerant pipeline and the water pipe is shown in Fig. 2-5-2, and the specific support appearance can be determined according to the site conditions. The height of the U-shaped pipe clamp h = the diameter of the pipe containing insulation cotton - 5mm. The pipe support needs to be purchased by engineering department. The recommended material of the pipe support and pipe clamp is 304 stainless steel. When the pipe is a straight section, a support needs to be added every 1500mm; when the direction of the pipeline changes, it is necessary to add support at a position 500mm away from the place where the pipeline changes.

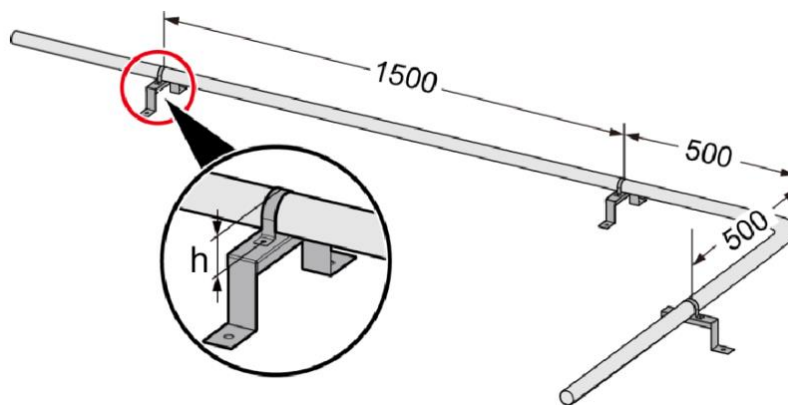

Fig. 2-5-2 Schematic diagram of pipeline support

2.5.4 Refrigerant pipeline connection

(1) Make sure that the inner wall of the copper pipe is clean before connection. Water entry is strictly prohibited

during the connection. After the connection, it is recommended to blow out impurities with nitrogen. The selection, arrangement and fixation of pipeline, system vacuuming and refrigerant charging must all be operated in accordance with industry standards. The design and construction process should consider pipeline pressure drop, compressor oil return, and reduce noise and vibration.

When welding, avoid burning the bottom plate, top plate, side plate, internal components, needle valves, other pipes, insulation cotton, cables, labels, etc., and take protective measures around the welding, such as laying wet cloth.

When welding, avoid too long time for system pipeline opening, which will affect system reliability. Generally, the opening time should not exceed 15min.

The recommended pipe size is “equivalent length” (see Table 2-5-8 for the equivalent length of each partial component), including the calculation of the resistance loss caused by the bend. Confirm the total pipe length on site, and then select the pipeline specifications according to Table 2-5-6.

Pay attention to sealing and protection when the pipeline passes through the bottom plate hole to prevent air duct leakage and copper pipe damage. The ends of the copper pipe should be sealed to prevent impurities from entering the refrigerant pipeline.

The refrigerant pipeline should be always wrapped with the insulation pipe.

(2) If the one-way equivalent length exceeds 30m, or the vertical height difference between the indoor unit and the outdoor unit exceeds the value shown in Table 2-5-7, please consult the manufacturer before installation to confirm whether additional pipeline extensions kit and other measures are needed;

Table 2-5-7 Vertical height difference between indoor unit and outdoor unit

Relative position	Value
Outdoor unit higher than indoor unit	Maximum: +20m
Outdoor unit lower than indoor unit	Maximum: -10m

(3) The pipe size recommended in Table 2-5-8 is the equivalent length, and the resistance loss caused by the bend and the valve has been calculated. The installer should confirm whether it is appropriate according to the on-site situation.

Table 2-5-8 Equivalent length of each partial component

Outer diameter of liquid pipe (inch)	Equivalent length (m)		
	90° bend	45° bend	T joint
5/8	0.27	0.15	0.76
3/4	0.3	0.18	0.76
7/8	0.44	0.24	1.1
1-1/8	0.56	0.3	1.4

Note

An oil collector (oil trap) should be installed at the vertical height of the gas pipe every 5~6m. For details, please consult our company;

1. Pay attention to sealing and protection when the pipeline passes through the bottom plate hole to prevent air duct leakage and copper pipe damage;
 2. The refrigerant pipeline should be always wrapped with insulation cotton.
-

There are refrigeration pipe joints and labels on the top (non-standard) and bottom (standard) of the unit. You can choose to connect the pipe from the top or from the bottom as needed; considering the influence of the pipe diameter on the system pressure drop, please select the diameter of the connecting copper pipe of the indoor and outdoor units in accordance with the recommended size in Table 2-5-6.

(4) Connect the copper pipes between indoor unit and outdoor unit (exhaust pipe, liquid pipe)

Refer to Fig. 2-3-3 and Fig. 2-3-4 for the direction and welding of the copper pipes of the indoor and outdoor units. Note that the direct connection pipes of the indoor and outdoor units need to be wrapped with insulation cotton.

(5) Add extension assembly (applicable to on-site installation)

When the equivalent length of the pipeline exceeds 30m, an extension assembly should be installed. Refer to Fig. 2-3-3 for connection.

Note

When installing extension assembly on site, please note that the flow direction of the refrigerant must be consistent with the direction marked on the valve body.

(6) Add cryogenic components (applicable to on-site installation)

Cryogenic components need to be installed when the outdoor temperature in winter is lower than -20°C. Refer to Fig. 2-3-3 for connection.

(7) Connect water pipes

1) Connect the drain pipe

a) Top layout model: Only connect the condenser drain pipe of the strong drain pump, and the natural drain pipe keeps blocked as being delivered;

b) Bottom layout model: It is recommended that the condenser drain pipes of the natural drainage and strong drain pumps are both installed and connected to two different condensate drainage ports (mustn't be connected in series to one drain port); if only one drainage port can be installed on site, it is recommended to install the natural drain pipe, keep the drain pipe of strong drainage pump in tight and blocked state, and disable the forced drainage of condensate pump (in installation parameters of unit touch screen -- model function menu).

c) The outside of the drain hose should be wrapped with insulation cotton to prevent condensation.

2) Connect wet-film humidification inlet pipe (when equipped with wet-film humidification)

When configuring wet film humidification, you need to prepare a hose clamp and the above-mentioned water inlet hose, connect with the water inlet solenoid valve, and tighten as shown in Fig. 2-5-3.

Where the main pipeline pressure may exceed 700kPa, a pressure reducer should be installed. Where the main pipeline pressure is lower than 100kPa, there should be a collection tank and a water pump system.

Note

The main inlet pipe must be made in accordance with local regulations.

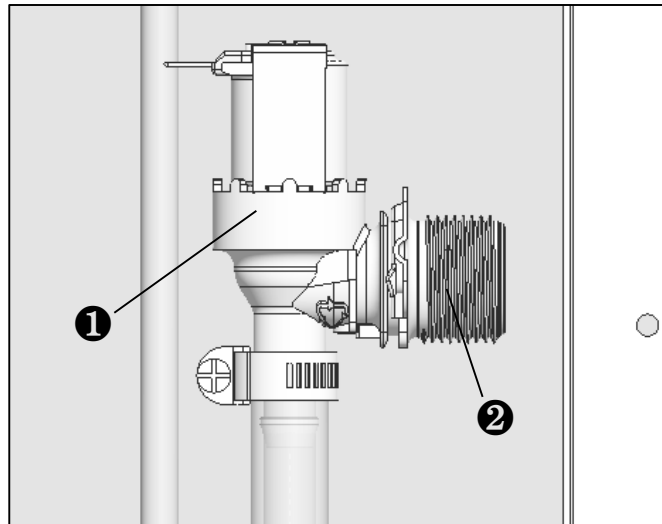

Item	Description
①	Water inlet solenoid valve
②	External thread G3/4 connector

Fig. 2-5-3 Fastening of wet film humidification water inlet hose

(8) Nitrogen filling

Connect the pressure gauge and the nitrogen cylinder at the needle valve of the indoor unit liquid pipe and the exhaust pipe with a refrigerant hose, open the pressure reducing valve on the nitrogen cylinder, and fill the needle valve on the suction and exhaust pipe with 3MPa nitrogen at the same time, and keep the pressure for 24 hours. There should be no decrease in system pressure when the ambient temperature is similar before and after the pressure holding.

Note

If the pressure value drops, you must use soapy water or a halogen leak detector to find and repair the leak.

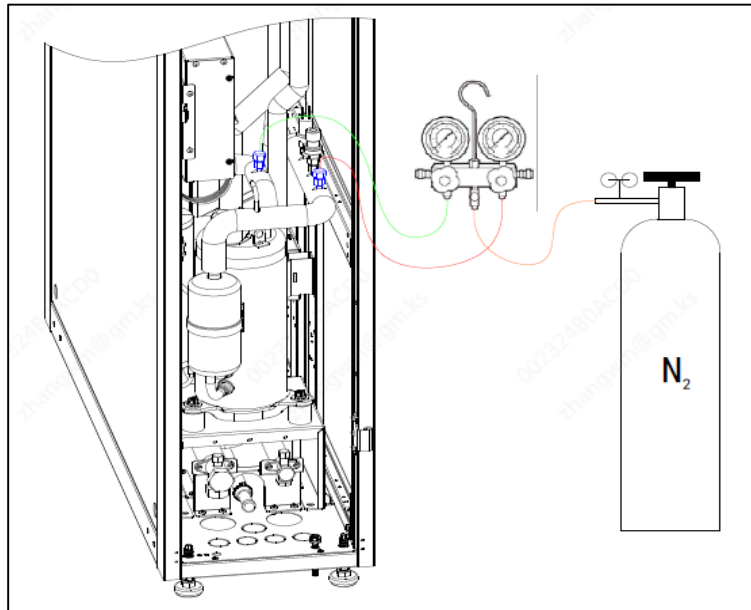
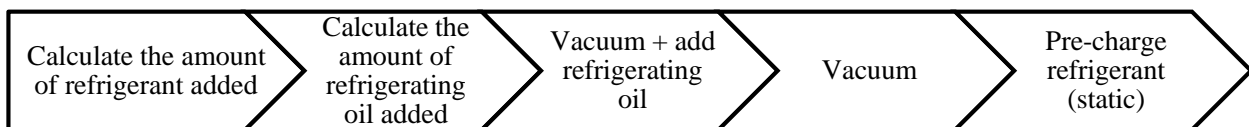

Fig. 2-5-4 Nitrogen filling

2.5.5 Pre-charging refrigerant and adding refrigerating oil

(1) Operation process



Before vacuuming, power on the unit and enter the maintenance page, select the manual mode page, turn on the vacuuming mode to open the expansion valve and the liquid pipe solenoid valve, and then add refrigerant oil according to Fig. 2-5-6. Note that the refueling position is at the needle valve of the suction pipe.

(2) Calculate the amount of refrigerant added

After the on-site pipeline connection is completed, determine the charge amount of the refrigerant in the system according to the length of the connecting pipeline of the indoor and outdoor units.

Table 2-5-9 shows the standard refrigerant charge volume of the system with a one-way connecting pipe of 10m. If the one-way connecting pipe between the indoor unit and the outdoor unit is within 10m, simply charge according to the refrigerant charge in Table 2-5-9 after vacuuming on site; if the one-way connecting pipe exceeds 10m, refrigerant addition = standard charge + additional amount of refrigerant.

The additional amount of refrigerant is calculated according to the following formula:

Additional amount of refrigerant (kg) = Additional refrigerant amount per unit length of liquid pipe (kg/m) × length of extended liquid pipe (m) + additional amount for cryogenic components (or additional amount for energy-saving modules)

Wherein, the length of the extended liquid pipe (m) = total length of the liquid pipe between indoor unit and outdoor unit (m) - 10m

“Additional amount of refrigerant per unit length of liquid pipe” is shown in Table 2-5-10.

Table 2-5-9 Standard charge amount of refrigerant for a system with 10m connecting pipe

Model	Standard charge (kg)	Additional amount for cryogenic components (kg)	Additional amount for energy-saving modules (kg)
FS012	3.8	2.4	21.5
FS025	6.2	6.0	21.5
FS030 ^①	8.5	6.0	21.5
FS030/040 ^②	11.5	6.0	21.5
FS050	13.0	11	21.5
FS060	14.0	11	21.5
FS070	16.5	11	21.5

Note: ① 300mm wide model, ② 600mm wide model.

Table 2-5-10 Additional amount of refrigerant per unit length corresponding to different outer diameters of liquid pipes

Outer diameter of liquid pipe (mm)	Addition amount of refrigerant per unit length (kg/m)	Outer diameter of liquid pipe (mm)	Addition amount of refrigerant per unit length (kg/m)
9.52	0.060	19	0.245
12.7	0.107	22	0.321
15.88	0.174	25	0.431

The static refrigerant charge is shown in Fig. 2-5-5. If the refrigerant can't be added when the refrigerant charge in the system is large and the charge reaches a certain amount during the static charge process, but the refrigerant charge hasn't reached the required volume, it needs to be charged according to the dynamic charging method introduced in Chapter 4.

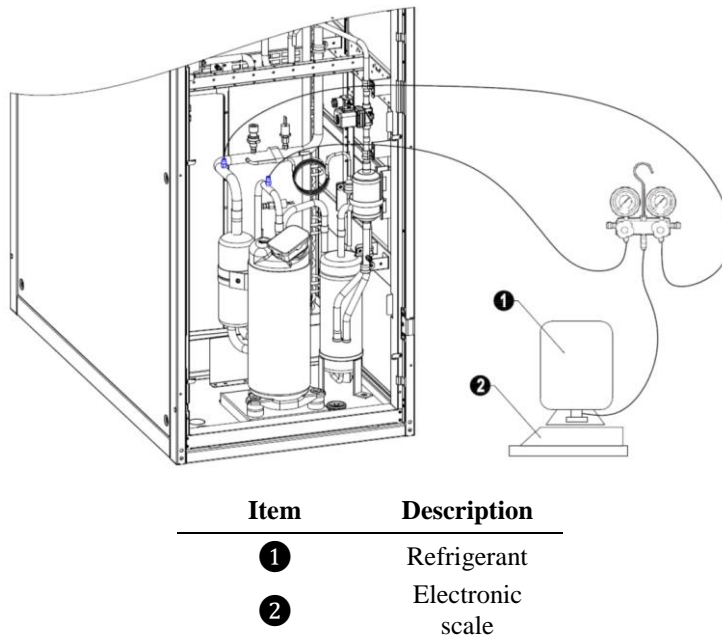

Fig. 2-5-5 Static refrigerant charge

(3) Calculate the amount of refrigerating oil added

The units have been added with some refrigerating oil before leaving the factory. It can meet the requirements of 30m one-way connecting pipes. If the one-way connecting pipe is more than 30m, the refrigerating oil shall be calculated and added according to the following requirements.

The amount of refrigerating oil to be added to the system (kg) = [(length of one-way connecting pipe -30m) × additional amount of refrigerant per unit length of liquid pipe + (additional amount for cryogenic components or additional amount for energy-saving modules)] × 0.04.

If the one-way connecting pipe of the system is less than 30m, the amount of refrigerating oil added only needs to be calculated for the cryogenic components or energy-saving modules, namely:

The amount of refrigerating oil to be added to the system (kg) = (additional amount for cryogenic components or additional amount for energy-saving modules) × 0.04.

Please consult the manufacturer’s after-sales personnel for the types and recommended models of refrigerating oil corresponding to different models and compressors.

Note

1. The amount of refrigerating oil should be calculated before the refrigerant is charged, and the addition should be completed during the vacuuming process, as shown in Fig. 2-5-6;
2. The refrigerating oil should be charged into the needle valve in the suction pipe.

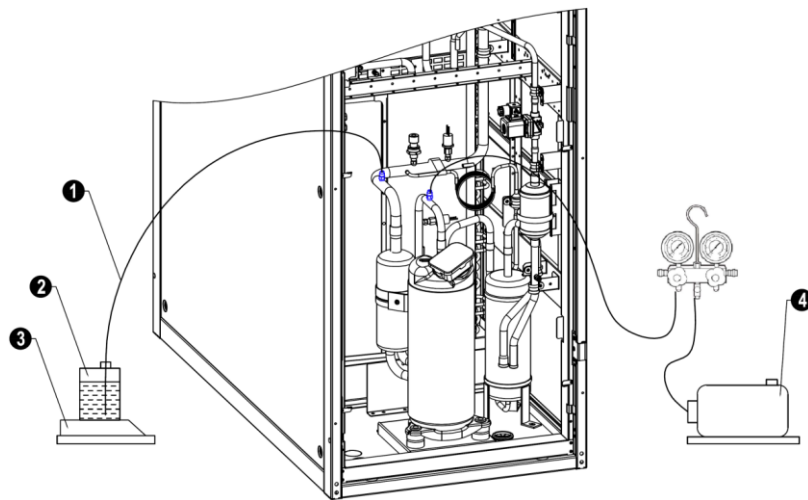

Item	Description
①	Refrigerant hose
②	Compressor refrigerating oil
③	Electronic scale
④	Vacuum pump

Fig. 2-5-6 Add refrigerating oil

Note: Please consult our after-sales service personnel for the types and recommended types of refrigerating oil

corresponding to different models and compressors.

2.6 Inspection Items for Installation

1. Leave a certain space around it for the convenience of equipment maintenance;
2. The equipment is placed vertically, and the installed fastening parts have been locked;
3. The pipes connecting the indoor and outdoor units have been installed;
4. The drain pipe has been connected;
5. The water supply pipe of the humidifier has been connected (when humidifier is configured);
6. All pipe joints have been tightened;
7. The fasteners used for transportation have been removed;
8. After the equipment is installed, the debris in or around the equipment has been removed (e.g. transportation materials, structural materials, tools, etc.); after all contents have been checked and confirmed to be correct, perform electrical installation operations.

Chapter 3 Electrical Installation

This chapter introduces the electrical installation of FocusAir series air conditioners, including task introduction, installation precautions, indoor unit wiring, connecting outdoor unit power cords, and installation inspection.

3.1 Wiring Content

3.1.1 Lines that need to be connected at the installation site:

1. Indoor unit power cord;
2. Outdoor unit power cord;
3. Input and output control lines of the units.

3.1.2 Installation precautions

1. The connection of all power cords, control wires and ground wires must comply with the national and local electrician regulations;
2. For full load current, please refer to the nameplate of the equipment. The cable size should conform to the local wiring rules;
3. Main power requirement: 380V/50/60Hz 3N~; Standby power requirement: 380V/50/60Hz 3N~;
4. Electrical installation must be carried out by qualified personnel;
5. Before connecting the circuit, measure the input power voltage with a voltmeter and make sure that the power is off.

3.2 Indoor Unit Wiring

The unit has reserved user inlet holes at the top and bottom, and is affixed with indication marks. You can choose to route from the top or from the bottom as needed.

3.2.1 Location of electrical interfaces of indoor unit

Open the rear door of the indoor unit to expose the interfaces of the electric control box. There are certain differences in the layout of the electric control box of different units. Please check the circuit diagram and indication labels for details.

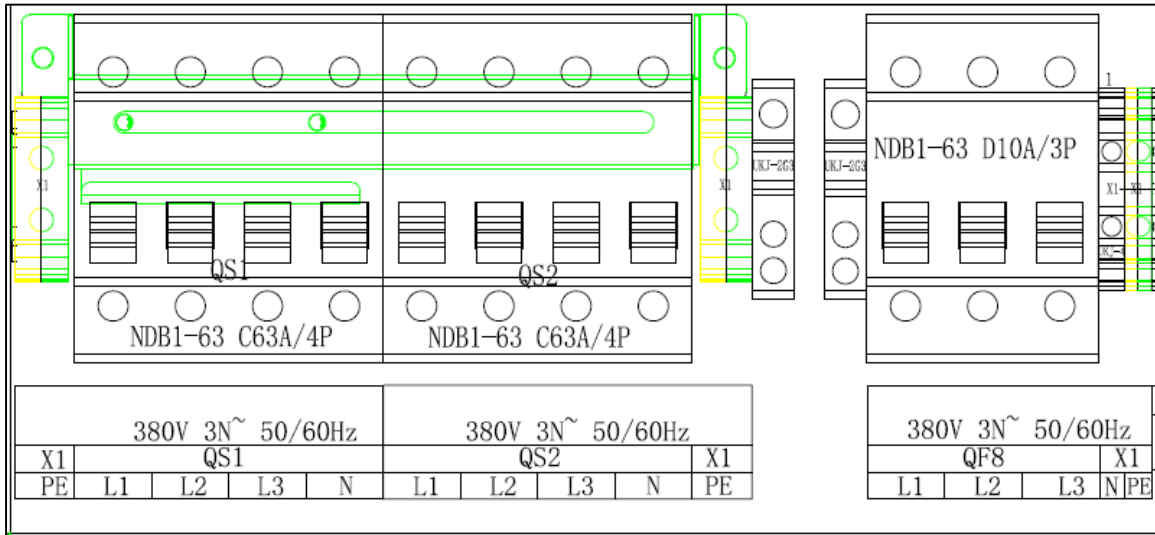

Label	QS1	QS2	QF8
Name	Main power supply	Standby power supply	Outdoor unit power supply

Fig. 3-2-1 Indoor unit wiring terminals

3.2.2 Connect power cords of the indoor unit

The recommended power cord specifications (according to the national standard) are shown in Table 3-2-1.

Table 3-2-1 Electrical parameters of unit

Model	Configuration	Maximum operating current-A	Recommended power cord specification -mm ² (copper core)
FS012 series	Cooling model	17.5	4*6.0+1*6.0
	Cooling + humidification model	18.0	4*6.0+1*6.0
	Constant temperature and humidity model	23.9	4*6.0+1*6.0
FS020~25 series	Cooling model	20.0	4*6.0+1*6.0
	Cooling + humidification model	20.5	4*6.0+1*6.0
	Constant temperature and humidity model	30.0	4*6.0+1*6.0
FS030 series	Cooling model	30.0	4*6.0+1*6.0
	Cooling + humidification model	30.5	4*6.0+1*6.0
	Constant temperature and humidity model	36.5	4*10+1*10
FS035~40 series	Cooling model	32.0	4*10+1*10

Model	Configuration	Maximum operating current-A	Recommended power cord specification -mm ² (copper core)
	Cooling + humidification model	32.5	4*10+1*10
	Constant temperature and humidity model	38.5	4*16+1*16
FS050-070 series	Cooling model	46.0	4*16+1*16
	Cooling + humidification model	46.5	4*16+1*16
	Constant temperature and humidity model	55.0	4*16+1*16

Table 3-2-2 Signal cable specifications

Signal line type	Recommended cross-sectional area/mm ²
Indoor and outdoor unit communication line	2*0.5
Power & environment monitoring communication line	2*0.5
Group control communication line	2*0.5
Note: The communication lines need to be outdoor shielded lines.	

The electric control layout of the indoor unit of air-cooled inverter in-row air conditioners is shown in Fig. 3-2-2. The half-cabinet inverter and the electric control are concentrated on one side, and the full-cabinet electric control box is separated from the inverter. Wherein, the electric control box of the half-cabinet model is pull-out type for easy maintenance, while the electric control box of the full-cabinet model is fixed; the air-break switch of the electric control box is connected to the corresponding end of the external power supply. Wrong wiring sequence may cause damage to the equipment and endanger personal safety.

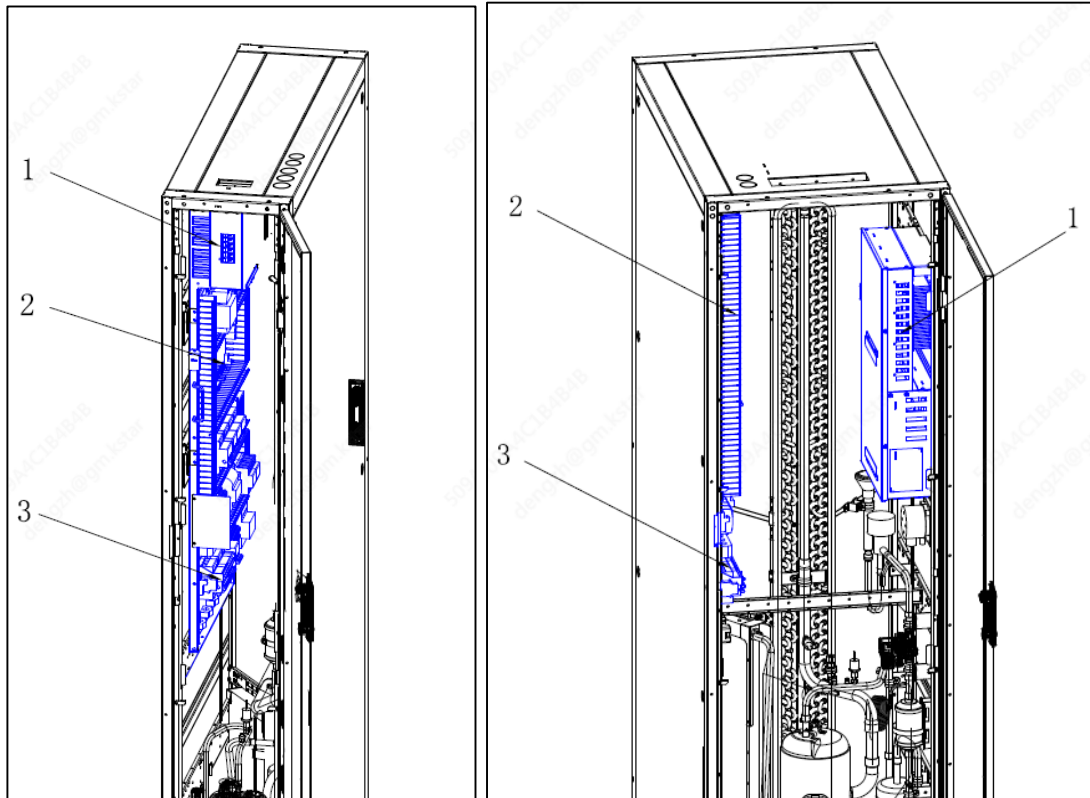

1. Inverter, 2. Main controller, 3. Customer wiring part

Fig. 3-2-2 Layout of electric control box

The indoor unit customer wiring part reserves air-break switch for outdoor unit power supply, as shown in Fig. 3-2-1. You can choose the power supply method of outdoor unit according to the on-site situation.

Note

The cable size should comply with local wiring regulations.

3.2.3 Connect control lines

Refer to the circuit diagram and indication labels as shown in Fig. 3-2-3 to complete the control line connection;

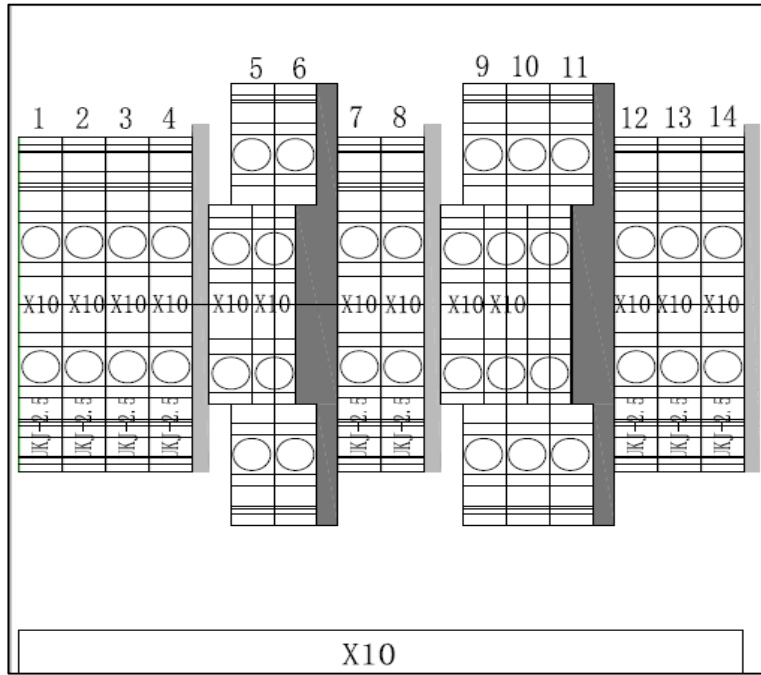

S/N	1	2	3	4	5	6	7	8	9	10	11	12	13	14
Name	COM		Remote	Smoke	Group control		Power & environment		Outdoor/Fluorine pump/Remote temperature and humidity			Common alarm		
					H	L	A	B	A	B	GND	NO	NC	COM

Terminal block definition

Fig. 3-2-3 Signal wiring terminal

⚠ Warning

Before connecting the control lines, the wiring personnel must take appropriate ESD measures.

(1) Connect communication lines of indoor and outdoor units

This unit needs to transmit data with the outdoor unit through RS485 communication. The wiring ports of the indoor unit are the outdoor (A), outdoor (B), and GND of the terminal block, corresponding to X1 (A2+), X2 (B2-) and GND of the X1 terminal block of the outdoor unit.

(2) Power & environment communication wiring

When you need to use the power & environment monitoring function, the field wiring and parameter settings are as follows:

1) Connect the Power & Environment (A) and Power & Environment (B) ports of the terminal block to the positive and negative ports of the monitoring system interface respectively.

2) On the display screen, enter the “Installation parameters”→ “Function settings” menu, set the “Remote communication address” to be consistent with the monitoring system.

(3) Group control communication wiring

The group control function can realize networking management of up to 32 units (address 00~31). The communication interfaces are a set of CAN interfaces. When the group control function is needed, the middle jumper cap R36 on the main control board must be unplugged first. If there are no more than 2 units, there is no need to unplug the jumper cap; when there are more than 2 units, unplug the jumper cap of the middle unit according to the connection sequence; do not unplug the caps of the first and the last jumper. The field wiring and parameter settings are carried out as follows:

- 1) Connect the group control communication lines from the group control (H) and group control (L) ports of the previous unit terminal block to the group control (H) and group control (L) ports of the next unit terminal block in sequence until the last unit.
- 2) Parameter settings must be performed for each unit. On the display screen, enter the “Installation parameters” → “Function settings” menu, set the “Group mode” parameter to “Group control”, and then set it as appropriate.
- 3) When a non-host online unit is powered off, offline, shuts down due to fault, fan shuts down due to fault, shuts down by local button or shuts down remotely (dry contact/communication), the unit exits the rotation queue and automatically activates one standby unit; every time the above situation occurs, one standby unit will be automatically added until all the standby units are put into operation. When the host is powered off or offline, all the standby units will activate and work independently; the units will restore previous state after the fault is restored.
- 4) Remote shutdown

The remote shutdown switch can be enabled in “Function settings” of the installation parameters.

5) Common alarm terminal

External common alarm terminal can be connected. It is controlled by the circuit board common alarm relay and its output is used to connect to external alarm devices, such as smoke alarms. When a serious alarm occurs, the contact is closed. This can be used to issue remote alarms, give signals to building management systems or dial paging systems automatically. The user needs to provide the loop power supply for the common alarm system.

See the circuit diagram and labels for other terminal definitions.

3.3 Outdoor Unit Wiring

3.3.1 Location of electrical interfaces of outdoor unit

The power supply of the outdoor unit can be obtained from the indoor unit electric control box or from the on-site power distribution cabinet. It is recommended to connect from the indoor unit electric control box. The air-break switch QF1 of outdoor unit power interface is shown in Fig. 3-3-1 (the picture is for reference only). If the outdoor unit is powered by the on-site power distribution cabinet, please refer to the local power distribution standard and the manual of the power distribution cabinet, and refer to Table 3-3-1 to select the unit air-break switch. No matter

where the outdoor unit is powered from, ensure that the power phase, neutral wires and ground wires are correctly and reliably connected.

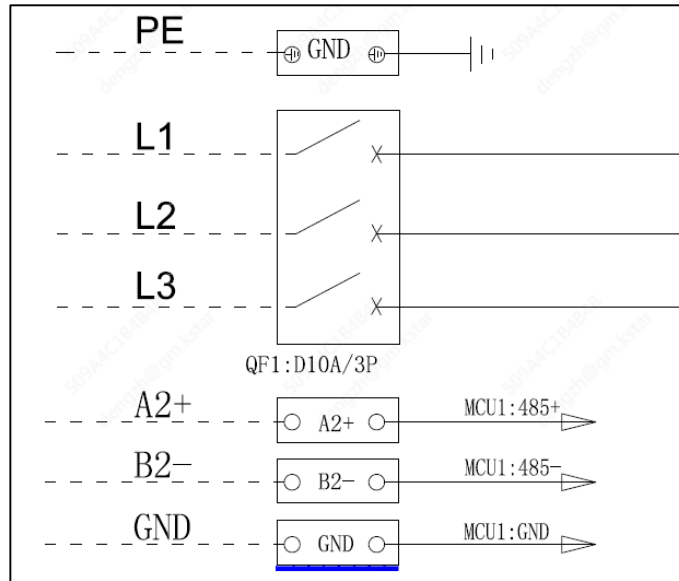

Fig. 3-3-1 Outdoor unit power terminal

Table 3-3-1 Power distribution parameters of the units

Outdoor unit model	Full load current	Recommended cable cross-sectional area	Recommended specifications of power distribution switch
KCS018	2.0A	1.5mm ²	10A
KCS024	2.5A	1.5mm ²	10A
KCS028	2.5A	1.5mm ²	10A
KCS032	2.5A	1.5mm ²	10A
KCS036	2.5A	1.5mm ²	10A
KCS042	2.5A	1.5mm ²	10A
KCS048	2.5A	1.5mm ²	10A
KCS054	2.5A	1.5mm ²	10A
KCS064	5.0A	2.5mm ²	10A
KCS072	5.0A	2.5mm ²	10A
KCS084	5.0A	2.5mm ²	10A
KCS096	5.0A	2.5mm ²	10A

Note

1. The cable size should conform to the local wiring rules, and the D-type circuit breaker should be used for the air-break switch.
2. After wiring, apply waterproof glue on the waterproof joint.
3. The cable should not be in contact with high-temperature objects (copper pipes and water pipes without insulation) in order to avoid damage to the insulation layer.

3.3.2 Wiring of indoor and outdoor unit communication lines

The communication lines of the indoor unit and outdoor unit are respectively connected to the corresponding

positions of the indoor unit from the first (A2+), second (B2-) and GND positions of the X1 terminal block of the outdoor unit (see the electrical schematic diagram of the indoor unit for details). The user shall provide the communication lines according to the actual installation position of the on-site unit. It is recommended to use RVVP two-core cable, and the minimum cross-sectional area of the core line shall not be less than 0.5mm². The location of the communication interface of the outdoor unit is shown in Fig. 3-3-2.

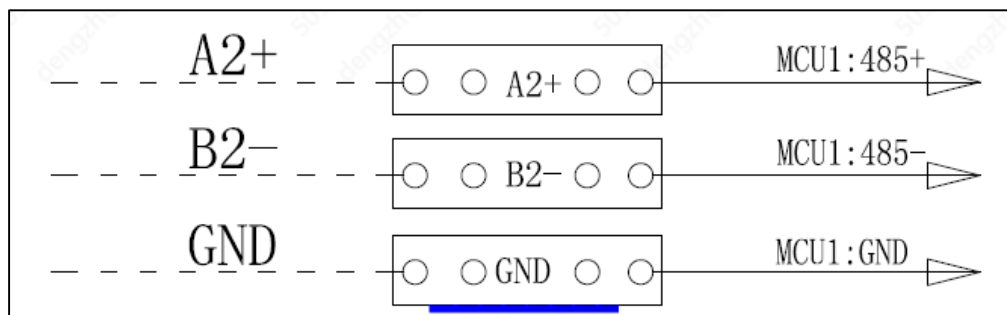

Fig. 3-3-2 Outdoor unit communication interface

Note

1. The cable size should conform to the local wiring rules;
2. After wiring, apply waterproof glue on the waterproof joint;
3. The cable should not be in contact with high-temperature objects (copper pipes and water pipes without insulation) in order to avoid damage to the insulation layer.
4. After wiring, the outdoor unit DIP must be set. For specific operations, refer to the circuit diagram of the outdoor unit.

3.4 Installation Check

After the electrical installation is completed, check to confirm that:

1. The power supply voltage is the same as the rated voltage on the equipment nameplate;
2. There is no open circuit or short circuit in the electrical circuit of the system;
3. The power cables and grounding cables to the disconnect switch, indoor unit and outdoor unit have been connected properly;
4. The rating of the circuit breaker or fuse is correct;
5. The control cables have been connected properly;
6. All cables and circuit connectors have been tightened, and the tightening screws are not loose.

After all the above contents are checked and confirmed to be correct, you can start commissioning.

Chapter 4 Commissioning

This chapter introduces the system commissioning and function test of the air-cooled in-row air conditioners, including preparation for commissioning and commissioning steps.

4.1 Electrical Layout

Please check the circuit diagram and labels of the unit for the position of each air-break switch.

4.2 Commissioning

4.2.1 Preparation for commissioning

Mechanical part

1. Ensure that the protective materials of the equipment for transportation have been removed;
2. The refrigeration piping system has passed the pressure leak test and confirmed to be conforming;
3. The total charge of the system has been roughly calculated, and the refrigerating oil has been added to the system;
4. The water supply pipe of the humidification system (when configured) has been reliably connected and checked for leakage in accordance with the specified material requirements;
5. After charging the refrigerant in static state, the compressor heating belt has been preheated for more than 12 hours;
6. Ensure that the temperature of the machine room is above 20°C and has a certain thermal load. If not, first use other heating devices or manually operate the unit and the heaters of adjacent equipment (to forcibly operate heaters of the unit, be sure to follow the procedures below to proceed to item 3 of *4.2.2 Commissioning Steps*) to preheat the machine room environment and ensure the rated heat load necessary for commissioning;
7. In some cases in winter, it is necessary to increase the condensing pressure to 26Bar by artificially shielding part of the condensing area and limiting the amount of cooling water.

Electrical part

1. Confirm that the main power input voltage is within $\pm 10\%$ of the nominal range of the rated voltage; the power isolation switch of outdoor unit condenser is closed;
2. Confirm that all electrical or control lines are correct, and tighten all electrical and control connections;
3. Power cables and low-voltage control cables must be arranged separately.

4.2.2 Commissioning steps

1. Disconnect the air-break switch corresponding to each component, close the isolating switch and control air-break switch, and check the control voltage;

2. Fan commissioning:

Close the air-break switch of the fan, tap “ON” on the touch screen to start, and check whether each fan is operating normally;

3. Water pump commissioning:

When a condensate drain pump is configured and needs to be drained by a water pump, enter the “Vendor parameters → Model settings” page to check whether the condensate drain pump function is disabled. If yes, set it to “On”;

Commissioning steps: when the air conditioner is connected to the power supply and shut down, enter the maintenance parameters, select manual mode, and manually turn on the condensate drain pump; or in running state, manually raise the condensate high water level switch for 5 seconds to check if the water pump is running normally.

4. Electric heating commissioning:

When heater is equipped, close the air-break switches of the fan and the electric heater, tap “ON” on the touch screen to enter heating mode, check whether the air supply temperature rises with your hand and determine whether the electric heater is working;

Heating mode triggering method:

Enter the “User parameters” page and set the “Set temperature” value to be 5°C higher than the current ambient temperature.

5. Humidifier commissioning:

Humidification mode triggering method:

Adjust the humidity setting so that it is 10% higher than the indoor relative humidity. At this moment, the control system should be able to trigger the humidification demand, and the humidifier starts to work. If the humidifier stops working when the set value is lower than the humidity in the machine room, it indicates that the humidification function is normal.

Note

After test, adjust the temperature and humidity settings back to the default settings or initial settings.

7. Compressor commissioning:

(1) If the static charging of the refrigerant does not reach the calculated charging amount, it is required to perform dynamic charging as follows:

- a. As shown in Fig. 4-2-1, connect the refrigerant cylinder, pressure gauge and the needle valve on the compressor suction pipe through the refrigerant hoses;
- b. Make sure that the outdoor unit is in power-on state, turn on the indoor unit fan and compressor air-break switch, enter the “User parameters” page, set the “Set temperature” value to the lowest, return to the home page of the touch screen, tap ON, and run in refrigeration mode. When the compressor is turned on for 5

minutes, slightly open the valve on the pressure gauge to slowly charge the refrigerant until the total refrigerant charge reaches the calculated charge, and close the valve. If the compressor is abnormal after running continuously for 10 minutes, it can be stopped, and the compressor commissioning is completed.

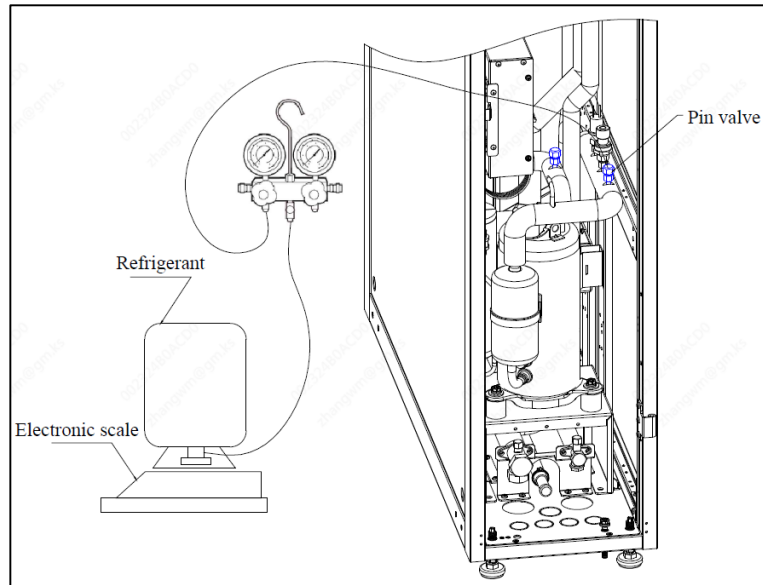

Fig. 4-2-1 Dynamic refrigerant charging

(2) If the refrigerant has been added before commissioning, trigger the refrigeration (compressor on) as follows:

Enter the “User parameters” page and adjust the temperature setting to make it 5°C lower than the indoor room temperature. The control system should be able to trigger the refrigeration demand and the compressor should run. If the compressor runs for at least 6 minutes without abnormality, it indicates that the refrigeration function is normal.

⚠ Warning

1. After the refrigerant is statically charged, it is forbidden to turn on the compressor immediately. Before starting up, ensure that the compressor crankcase heating belt has been preheated for more than 12 hours. If the preheating time is not enough, use other safe heat sources such as a thermoelectric hair dryer to heat the lower part of the compressor shell for about 30 minutes before starting in order to avoid the compressor starting with liquid, which will affect the service life of the compressor.
2. After test, adjust the temperature setting back to the default setting or initial setting.

4.2.3 Inspection after commissioning

1. Make sure that all points of the unit are firmly connected and there is no water leakage;
2. Check to make sure that all output functions are automatic;
3. Check to make sure that the temperature and humidity settings and accuracy are reasonable;
4. Check to make sure that other setting functions are reasonable.

Chapter 5 Basic Operation

5.1 Overview

This document describes the in-row air-conditioning manual operator (hereinafter referred to as the manual operator) and the indoor unit main board, as well as the connection and control methods and related function definitions.

The manual operator uses the display shell of the general machine room air conditioner as the appearance, which is a square chamfered design. The display is a 4.3-inch (FS012) or 7-inch (FS025~FS070) true color touch screen; the bottom has a USB interface, an RS485 interface and a power cord interface; the middle uses a text LCD as the human-machine interface, which adopts Chinese intuitive display and touch screen operation.

5.2 Introduction to the Touch Screen



Fig. 5-2-1a Front of the touch screen (4.3-inch)



Fig. 5-2-2a Bottom of the touch screen (4.3-inch)



Fig. 5-2-1b Front of the touch screen (7-inch)









Fig. 5-2-2b Bottom of the touch screen (7-inch)

5.3 Touch Screen Navigation

5.3.1 Function of icons

Table 5-3-1 Function of icons

No.	Icon	Name	Parameter description	Function description
1		Run	Running status query	1. Click this icon to query the current system status and equipment operating status.
2		Off	On/off control	1. On the home page, click this icon to turn on/off the unit. 2. The upper right corner of the screen is red when the unit is turned off, and green when the unit is turned on

No.	Icon	Name	Parameter description	Function description
3		Back	Back icon	1. On any page except the home, click this icon to return to the previous menu; 2. In parameter setting state, click this icon to give up the parameter editing, exit to the upper level parameter setting interface, and the data will not be stored.
4		Previous/Next	Page turning icon	1. Click this icon to turn the page on the multi-parameter page except the home page.
5		Home	Home Icon	1. Click this icon to return to the home page from any page except the home.
6		Alarm	Fault query; fault clearance; record query	1. Check the fault information of indoor unit and outdoor unit on the fault query page; 2. Choose whether to manually reset the current fault on the fault clearing page; 3. Select to view historical data, alarms and operation records on the record query page;
7		Settings	Set user parameters, installation parameters, manufacturer parameters	1. Set relevant operating parameters and alarm parameters on the user parameter page; 2. Set the communication method, temperature and humidity correction value on the installation parameter page; 3. Set function options, equipment parameters, and test mode on the vendor parameter page.
8		Maintenance	Maintenance settings	1. Manual commissioning; 2. Device running time; 3. Clear records.

5.3.2 Other functions

1. EEPROM data storage;
2. Real-time clock;
3. LCD backlight control;
4. Self-test.

5.3.3 Communication ports

Table 5-3-2 Definition of communication ports

No.	Mark	Name	Description	Remarks
1	COM1+,-	Mainboard communication port	Mainboard communication of the equipment	RS485
2	USB	Data interface	Program burning	USB

5.4 Basic Operation

5.4.1 User settings

1. Click on the parameter item that needs to be set to pop up the numeric keypad (when it exceeds the settable range, the parameter setting can't be continued), and click Enter key to confirm the modification after the parameter setting is completed;

2. Click the “Back” menu icon to return to the previous menu and cancel the operation;
3. Modify the operating status of equipment and devices directly by clicking on the parameters;
4. When there is no operation during the screen saver time, it will automatically return to the home page.

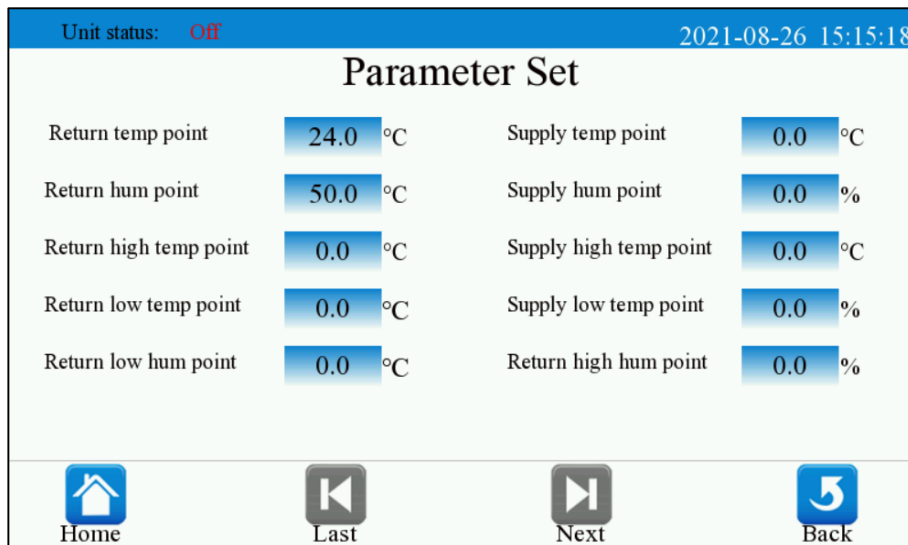

Fig. 5-4-1 Parameter setting page

5.4.2 Initial state of system

The system initializes after power-on, and the display shows service information and enters the home page.

5.4.3 Home page display

After power-on, the screen switches to the home page, as shown in the figure below:

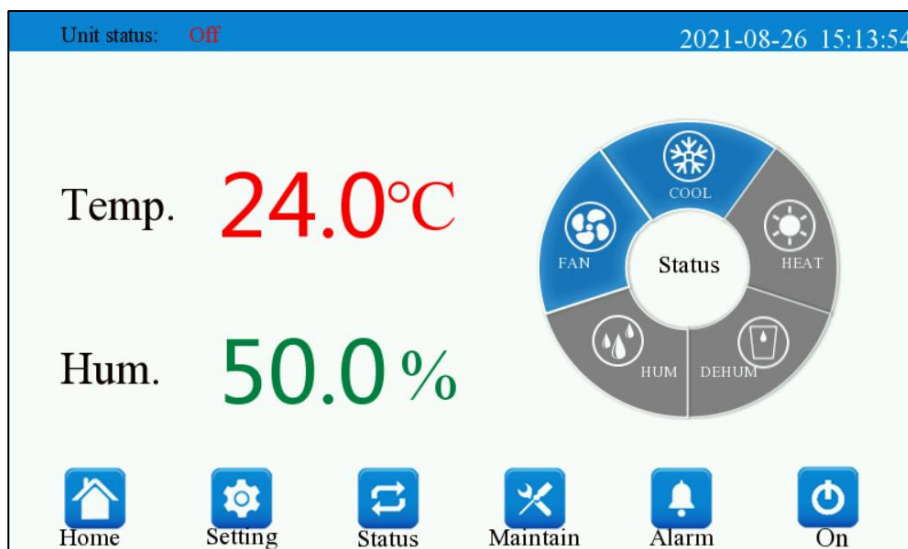

Fig. 5-4-2 Home page

The temperature and humidity on the home page are the current calculated indoor environment temperature and humidity. If the humidity sensor is invalid, this line will display (---); the temperature and humidity setting display area displays the set temperature and humidity;

Dial: Display the current unit state: standby (fan), refrigeration, humidification, heating, dehumidification, refrigeration & humidification, dehumidification & heating, heating & humidification.

5.4.4 Current fault view page

On the home page: **Unit status: Off**, if an alarm message appears, it means that the current system is faulty;

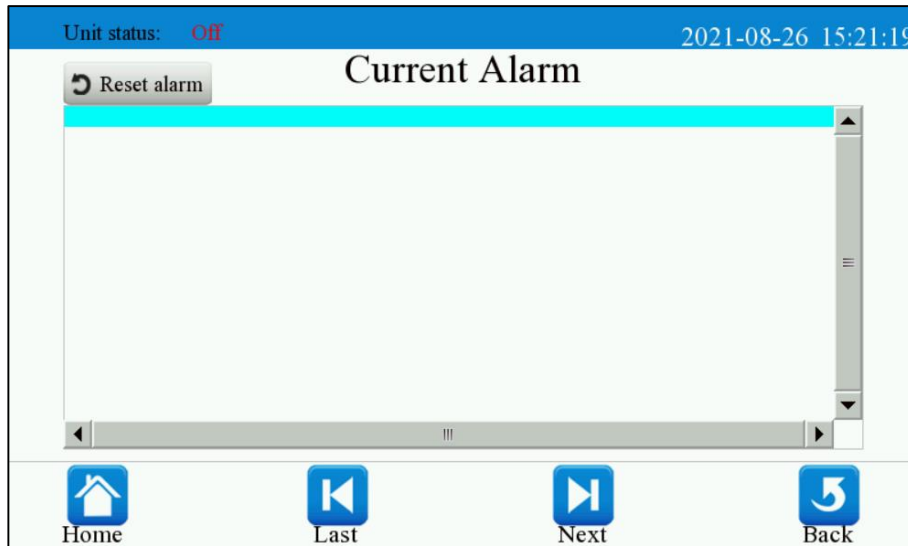



Fig. 5-4-3 Current fault interface

On the home page, click Alarm , enter “Query current fault” to view the current fault; after the fault is eliminated, enter “Reset alarm” on the alarm page to clear the current fault;

5.4.5 Current state view page

On the home page, press “”, enter “Running state” and view the current unit state;

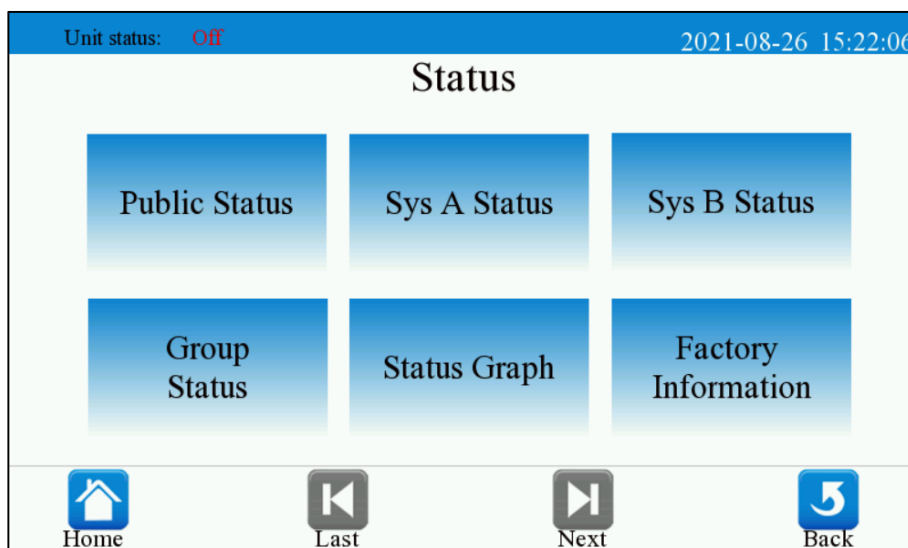



Fig. 5-4-4 Running state

5.4.6 View history

On the home page, click “” to enter the alarm page, and click to turn the page and enter the historical fault query page.

Click the drop-down icon of historical fault query to query the fault information of a certain day;

Click “Clear historical alarms” to clear historical records.

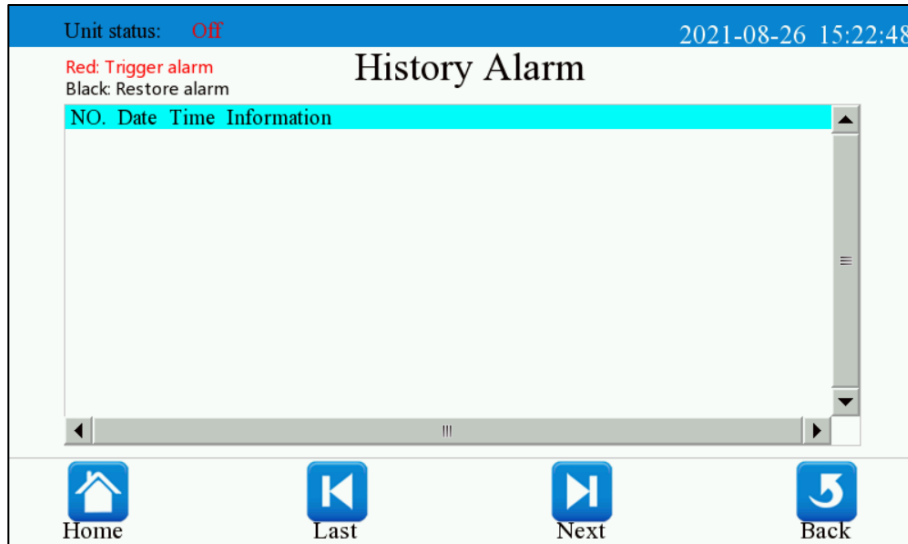

Fig. 5-4-5 Historical fault

5.4.7 Query of temperature and humidity curves

Select the temperature and humidity curve in the status bar to view the temperature and humidity curve over time, suspend the curve and clear the curve record.

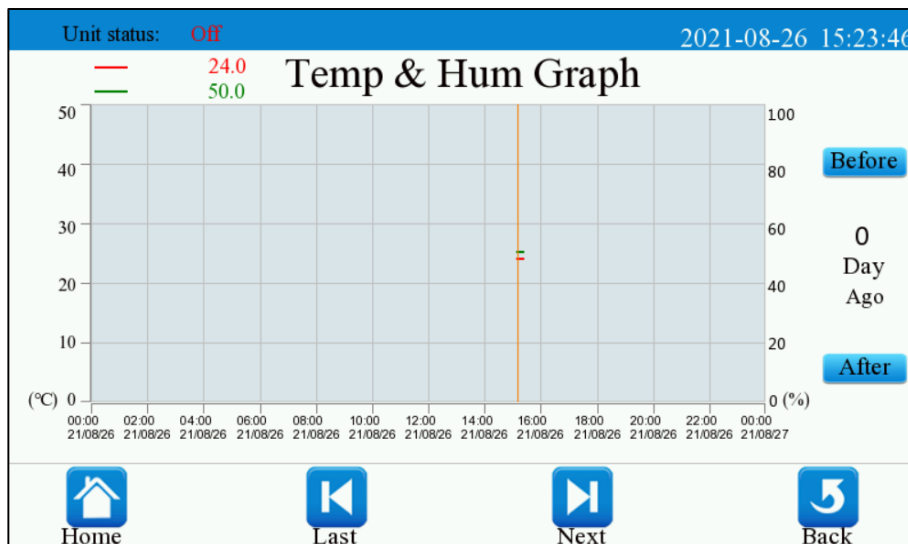

Fig. 5-4-6 Temperature and humidity curve

5.4.8 Manual control

On the home page, click “” to enter the maintenance page and then enter the manual mode control interface.



Fig. 5-4-7 Maintenance interface

5.4.9 Power-down memory function

If the system is powered off abnormally and powered on again, the system will operate in the working state before the power off, and restore parameters, temperature values, etc.

5.4.10 Power-on self-start

Once the power supply is restored after a power outage, the control panel can automatically start according to the state before the power outage.

5.4.11 Real time clock

It is written in the factory. You can click the time setting on the user parameter interface, click the corresponding number to pop up the keypad and then modify it directly.

5.4.12 Communication

It can communicate with the main board through the RS485 interface on the control board in accordance with the requirements of the communication protocol. Communication mode: serial asynchronous half-duplex;

Baud rate: 9600BPS;

5.4.13 Power on/off

On the home page, click the ON/OFF icon to perform the startup and shutdown operation. The home page will display the current state of the unit. When the ON/OFF icon displays in red, it means the unit is off; to turn on, simply click the icon;

When the ON/OFF icon displays in green, it means that the unit is in power-on state.

5.4.14 Password input

In the password input or confirmation/deselection page, the operations are as follows:

When entering the password input interface, it is not selected by default; click the numeric keypad to input the password, and click Enter to enter the interface; Default password: user parameter 333, installation parameter and ; vendor password please contact the manufacturer.

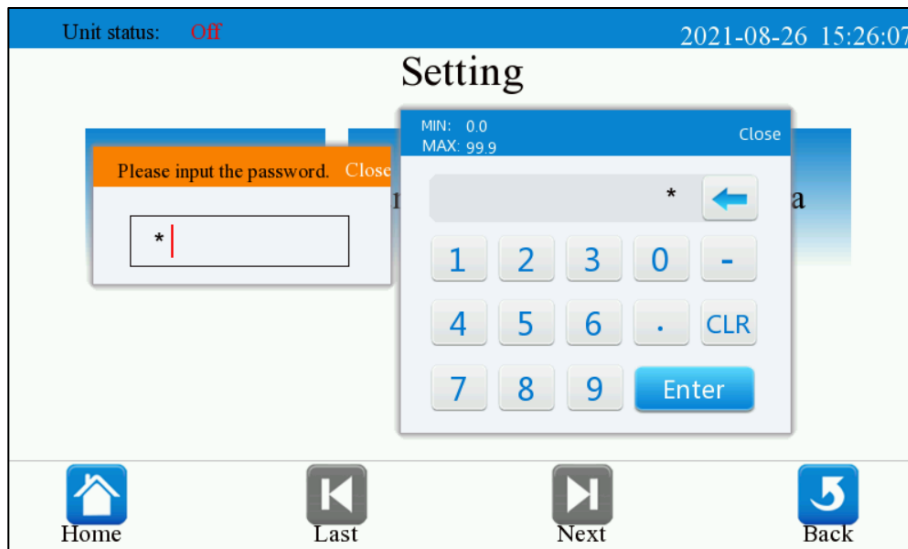

Fig. 5-4-8 Password input

5.4.15 User parameter settings

All user parameters are shown in Table 4.3-User parameter list;
If you need to modify a user parameter, follow the steps below:

Click the parameter to pop up the numeric keypad, input the parameter, and click Enter to modify it.

Table 5-4-1 Default user parameters

Parameters	Default value	Unit	Min.	Max.	Remarks
On/Off	1		0	1	0: Off 1: On
Supply air temperature setting	22	°C	22	45	Default temperature is supply air temperature control
Return air temperature setting	35	°C	27	45	/
Supply air humidity setting	50	%	10	95	Default humidity is return air humidity control
Return air humidity setting	30	%	10	95	/
Supply air high temperature alarm	32	°C	10.0	50.0	
Supply air low temperature alarm	12	°C	0.0	30.0	/
Return wind high humidity alarm	70	%	10	95	/
Return air low humidity alarm	15	%	10	95	/
Return air high temperature alarm	45	°C	10.0	50.0	/

Parameters	Default value	Unit	Min.	Max.	Remarks
Return air low temperature alarm	20	°C	10.0	50.0	/

5.4.16 Vendor parameters and parameter settings

See the system parameter table for all system parameters;

To modify a system parameter, the operation steps are the same as the user parameter setting method.

5.4.17 Maintenance parameters and parameter settings

See the system parameter table for all system parameters;

To modify a system parameter, the operation steps are the same as the user parameter setting method.

Chapter 6 Operation and Maintenance

This chapter mainly introduces the system operation and maintenance of FocusAir air conditioner.

6.1 System Diagnosis and Test

Warning

1. During the operation of the air-conditioning system, there may be lethal voltage in the equipment; all notes and warnings on the components, equipment and in this manual must be observed, or else it may cause personal injury or death.
 2. Only qualified repair and maintenance personnel can operate and handle these devices.
-

6.1.1 Electric control part

Electrical maintenance

Perform visual inspection and processing of electrical connections according to the following items.

1. Whole machine electrical insulation test: Find and deal with nonconforming contacts. During the test, disconnect the fuse or air-break switch of the control part to avoid damage to the control device due to high voltage;
2. Statically check whether each contactor is flexible, whether there is jamming or not;
3. Use a brush or dry compressed air to remove dust from electrical and control components;
4. Check whether the contacts of the contactor have arcing and burn marks. Replace the corresponding contactor in severe cases;
5. Fasten each electrical connection terminal;
6. Check whether the plug-in connectors are in good contact. If any looseness is found, the terminal should be replaced.

Control maintenance

Perform visual inspection, simple function inspection and processing of the control part according to the following items.

1. Check the appearance of the transformer and the output voltage (including indoor unit and outdoor condenser);
2. Check whether the surface of the control interface board and display control board is obviously aging;
3. Clean the dust and dirt on the electrical control components and control boards with a brush combined with electronic dust remover;

4. Check and tighten the output and input plug interfaces of the control interface board, including the connection between the display control board and the control interface board, and the connection between the control interface board and the temperature/humidity sensor board;
5. Check the connection between the user wiring terminal and the control interface board;
6. Check the output connection of the control interface board to each contactor, and the input connection of the high/low pressure switch, the filter blocking switch (if equipped) and the fan airflow safety switch (if equipped). Focus on the inspection of plug-in terminals, and replace immediately if loose or poor contact occurs;
7. Replace the control fuse (or air-break switch), control board and other electrical components that have problems;
8. Check the specifications and aging of the control connection or power connection, and replace the connection if necessary;
9. Check and calibrate the temperature and humidity sensor readings with a temperature and humidity measuring instrument with a higher level of measurement accuracy; note that the humidity control method should be relative humidity control during the process of calibrating the humidity sensor reading.
10. Adjust the set point and check the action of each functional component according to the control logic;
11. Simulate and check the working state of protection units such as high/low pressure alarm, high/low temperature alarm, and high water level alarm.

⚠ Warning

1. Before tightening any assembly connections and wiring connections, make sure that the power supply of the control unit is turned off;
 2. Do not use this sensor near flammable liquids or use it to detect flammable liquids.
-

6.2 Maintenance of Fan Components

Regular inspection items of fan components include: fan motor, impeller, etc. If necessary, please consult the manufacturer for more details.

6.2.1 Fan impeller

The fan should be checked regularly to see if it is firmly installed with the fan shaft. Rotate the fan impeller to ensure that it does not rub against the wind deflector.

6.2.2 Motor

Pay attention to the safety when the motor needs to be replaced due to abnormal sound, burnout, etc.

6.2.3 Fan replacement steps

Tools

Phillips PH2 screwdriver, slotted screwdriver (3x75, tip width * cutter bar);

Replacement steps for FS025/30 (300mm wide) series fans:

- (1) Off-line maintenance: open the rear door, remove the filter, and cut off the power supply of the air conditioner;
- (2) Pull out the plug-in terminals of the fan's power cord and signal line and cut off the cable ties corresponding to the fan's wiring harness to facilitate the following operations;
- (3) Loosen the screws of the fan fixing frame with a Phillips screwdriver and take out the fan assembly;

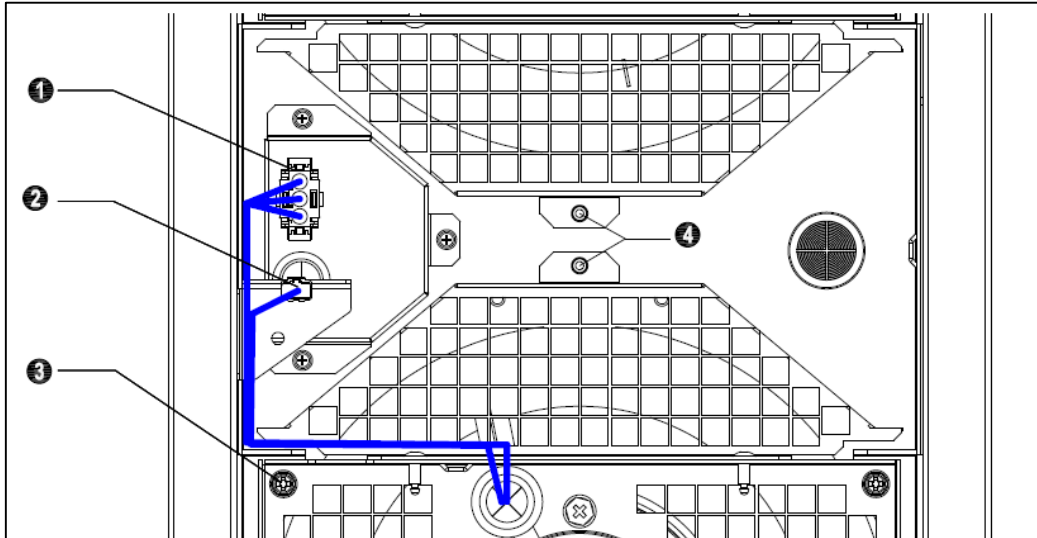

Item	Description
①	Fan power cord terminal
②	Fan signal line terminal
③	Fan fixing frame screw
④	Limit point of fan guard

- | | |
|---|--------------------------|
| ① | Fan power cord terminal |
| ② | Fan signal line terminal |
| ③ | Fan fixing frame screw |
| ④ | Limit point of fan guard |

Fig. 6-2-1 Fan components of 300mm wide model

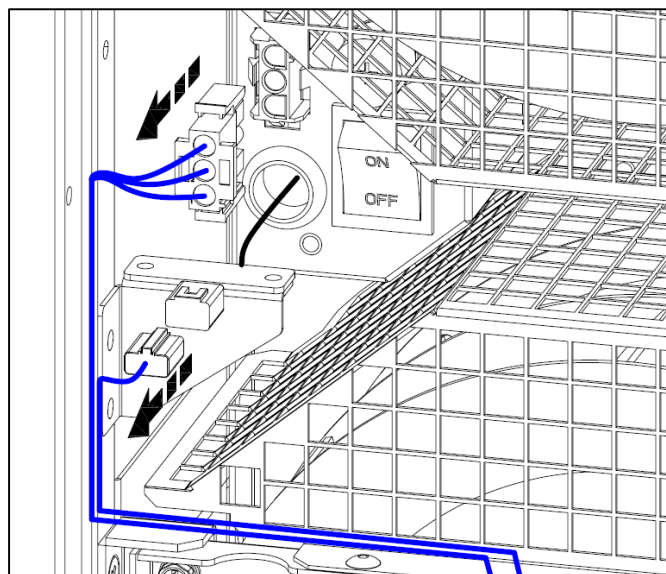

Fig. 6-2-2 Pulling out terminals of fan power cord and signal line

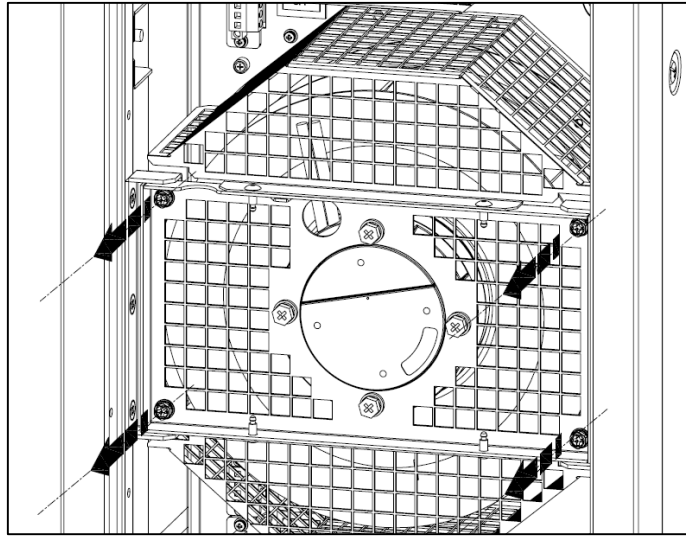

Fig. 6-2-3 Removing screws of fan mounting bracket

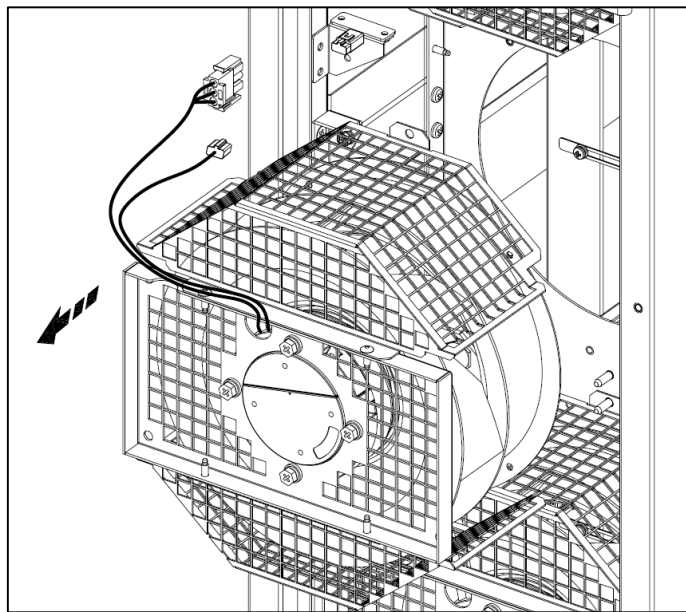
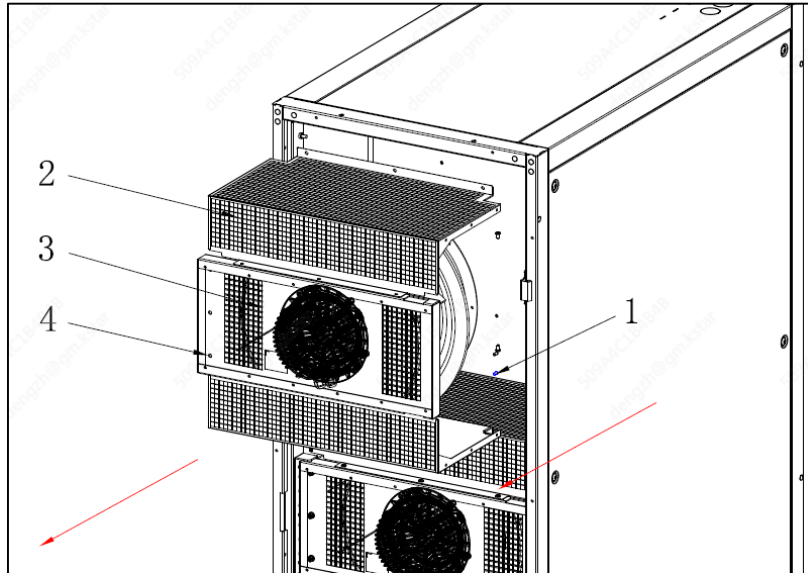

Fig. 6-2-4 Removing fan assembly

(4) Reinstall the new fan assembly according to steps 3~1.

Replacement steps for FS025-70 (600mm wide) series fan:

- (1) Open the rear door, remove the filter, and turn off the air-break switch on the customer junction box;
- (2) Open the front door, and unplug the plug-in terminals of fan power cord and the control line;
- (3) Remove the power cord and control line of the fan;
- (4) Remove the fixing screws of the fan mounting frame and take out the fan;



Item	Description
①	Limit point of fan guard
②	Protective net
③	Fan mounting frame
④	Mounting frame fixing screw

Fig. 6-2-5 Taking out fan assembly of 600mm wide model

6.3 Filter maintenance

When the filter is blocked or the filter maintenance alarm prompt appears, the filter needs to be removed and cleaned (washed) or replaced with a new one.

Replacement operation: Open the rear door of the unit, rotate the filter presser 90°, and then take out the filter.

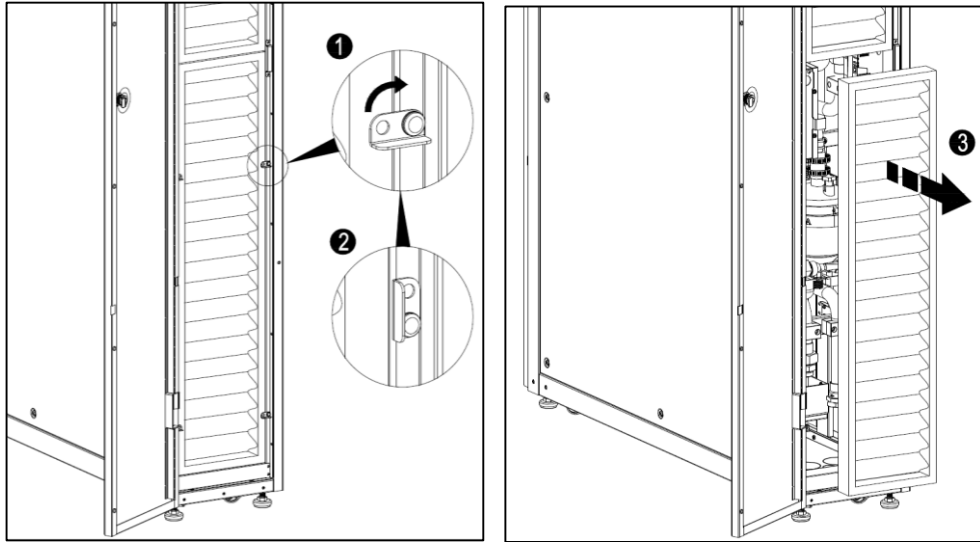

Fig. 6-3-1 Filter maintenance steps

6.4 Maintenance of Differential Pressure Switch

- (1) Remove the fixing screws of the differential pressure switch wiring cover, and take out the wiring cover;
- (2) Loosen the screws of the terminals (2, 3), and remove the connecting wire of the differential pressure switch;
- (3) Remove the 4 fixing screws from the base of the differential pressure switch, pull out the pressure tube, and then remove the differential pressure switch;
- (4) Adjust the pressure difference value of the new pressure difference switch to 300Pa (turn the middle knob to “300” to align with the red arrow).

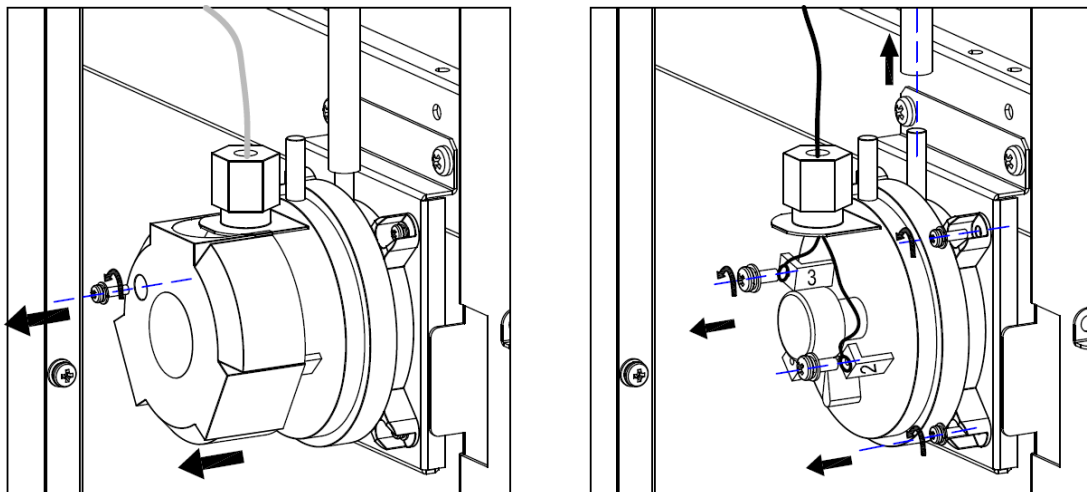

Fig. 6-4-1 Maintenance steps of differential pressure switch

6.5 Maintenance of Condensate Drain Pump (Optional)

Tools

Flat-head PH2 screwdriver

Pump component identification

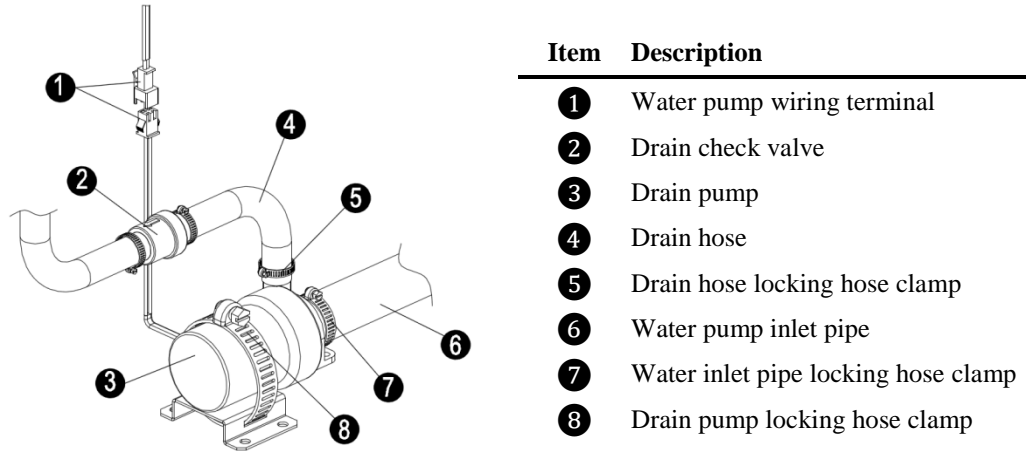

Fig. 6-5-1 Water pump maintenance

Water pump replacement steps:

- (1) Set the unit to the OFF state, open the rear door, remove the filter, and turn off the air-break switch of the unit;
- (2) Unplug the water pump terminal ①;
- (3) Remove the water pump locking hose clamp ⑧, water inlet pipe locking hose clamp ⑦, and drain hose locking hose clamp ⑤, and then take out the pump;
- (4) Install the new water pump according to steps 1 and 2.

6.6 Maintenance of Electric Heater (Optional)

Maintenance of electric heater for 300mm wide models:

- (1) Turn off the air-break switch of the electric heater, and turn off the input power air-break switch of the unit after the electric heater cools down;
- (2) Remove the fan 3, 4 components and the wind deflector according to the replacement steps of the 300mm wide model fan, and expose two PTC electric heaters;

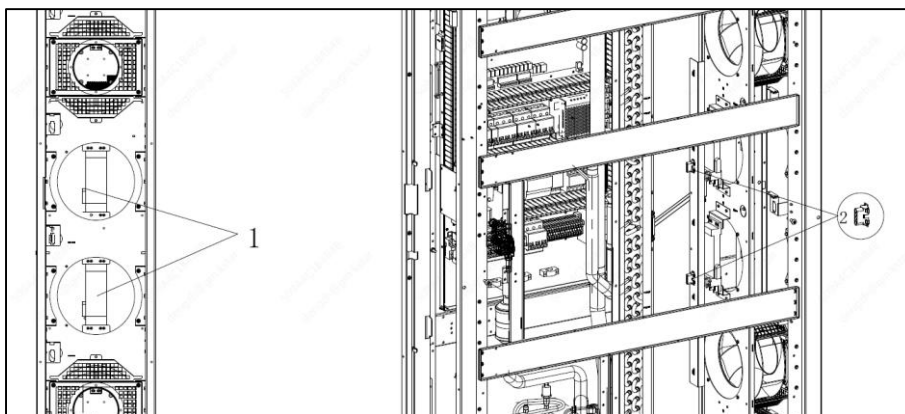

Item	Description
①	PTC electric heater
②	Electric heater wiring terminal

Fig. 6-6-1 Description of electric heater for 300mm wide model

(3) Reach out from the removed fan installation hole to pull out the electric heater wiring terminal;

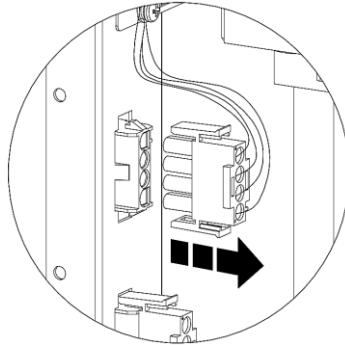
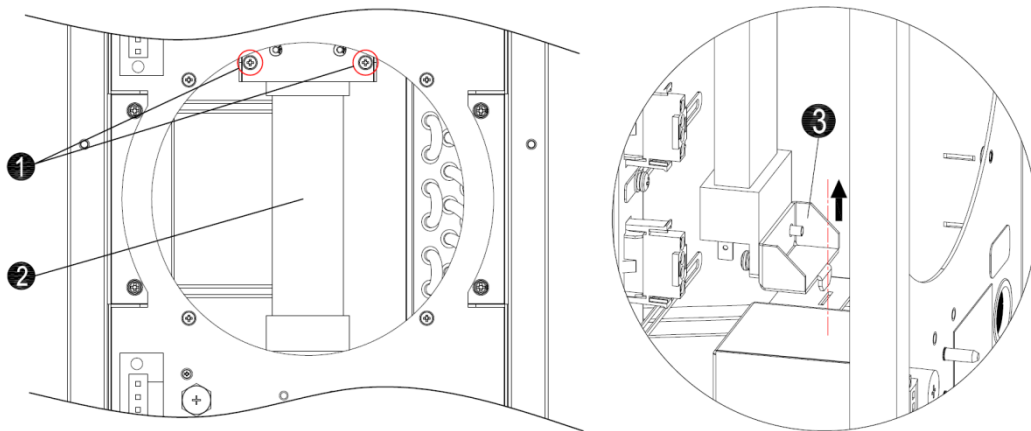

Fig. 6-6-2 Unplugging the electric heater wiring terminal

(4) Remove the electric heater fixing screw, and then take out the electric heater;



Item	Description
①	Electric heater fixing screw
②	PTC electric heater
③	Bottom fixing seat of electric heater

Fig. 6-6-3 Taking out the electric heater components

(5) Install the new electric heater components back according to the above steps 4~1.

Maintenance of electric heater for 600mm wide models:

- (1) Turn off the input power air-break switch of the unit;
- (2) Open the front door and remove the fixing screws of the electric heater protective net;
- (3) Unplug the electric heater wiring terminal;

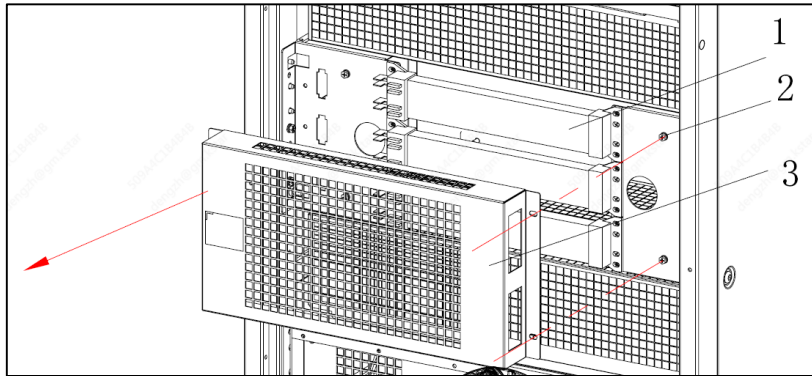

Item	Description
①	PTC electric heater
②	Protective net fixing screw
③	Protective net

Fig. 6-6-4 Taking out the electric heater protective net

- (4) Remove the fixing screws of the electric heater, and then take out the electric heater;
- (5) Install the new electric heater components back according to the above steps 4~1.

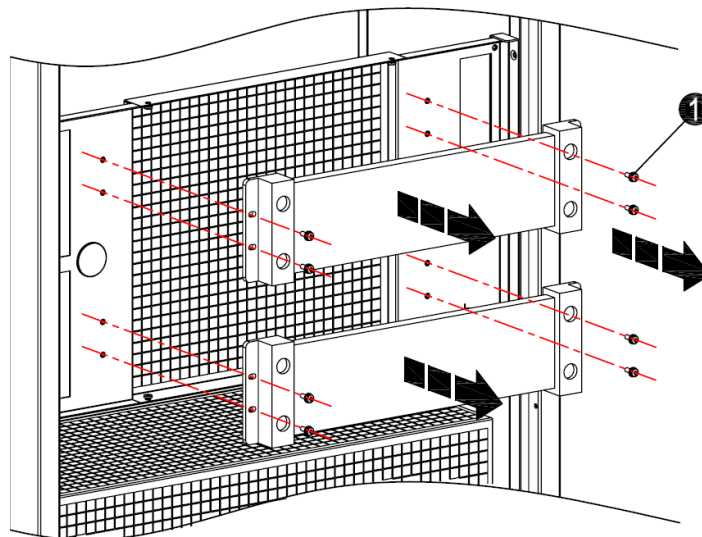

Item	Description
①	Electric heater fixing screw

Fig. 6-6-5 Taking out the electric heater components

6.7 Wet Film Humidification Maintenance (Optional)

6.7.1 Replacing wet film

- (1) Open the rear door and reach out to loosen the captive screws on the wet film module, as shown in Fig. 6-7-1;
- (2) Loosen the hose clamp connected to the water supply pipe on the wet film, lift the wet film up and pull it out as shown in Fig. 6-7-2, and replace it.

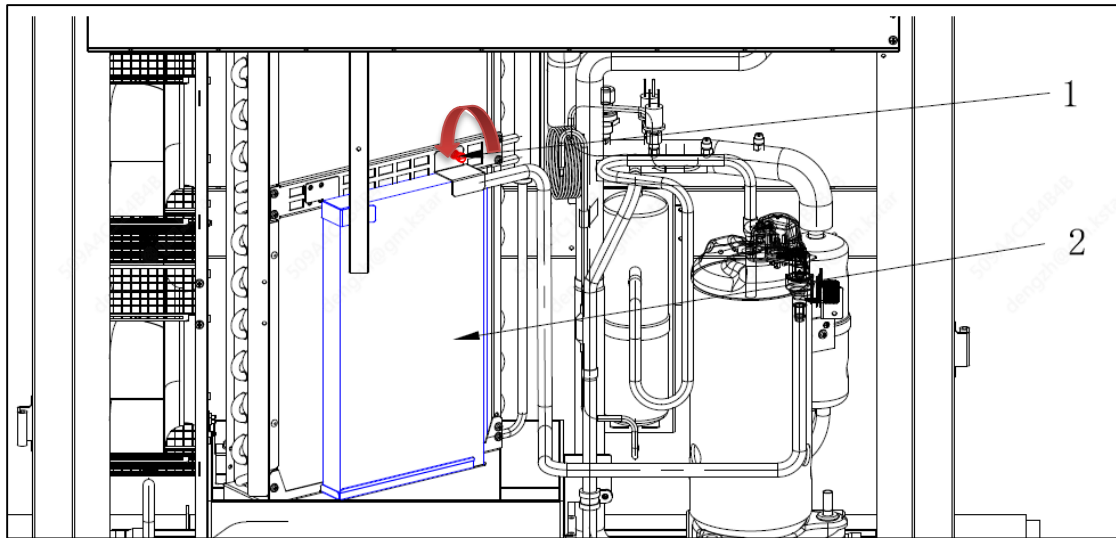

Item	Description
①	Captive screw
②	Wet film humidifier

Fig. 6-7-1 Loosening the screws

Note

Before replacing the wet film, make sure that the unit is powered off or shut down to prevent entering the humidification mode during the process of replacing the wet film and causing the wet film inlet pipe to spray water.

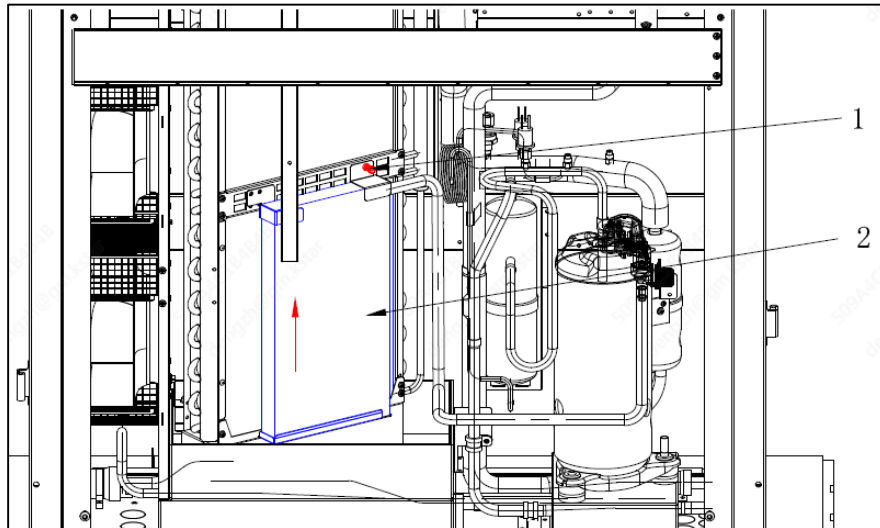

Fig. 6-7-2 Taking out the wet film

6.8 Maintenance of Electrode Humidifier

Tools

Phillips and slotted PH2 screwdriver

Humidifier component identification

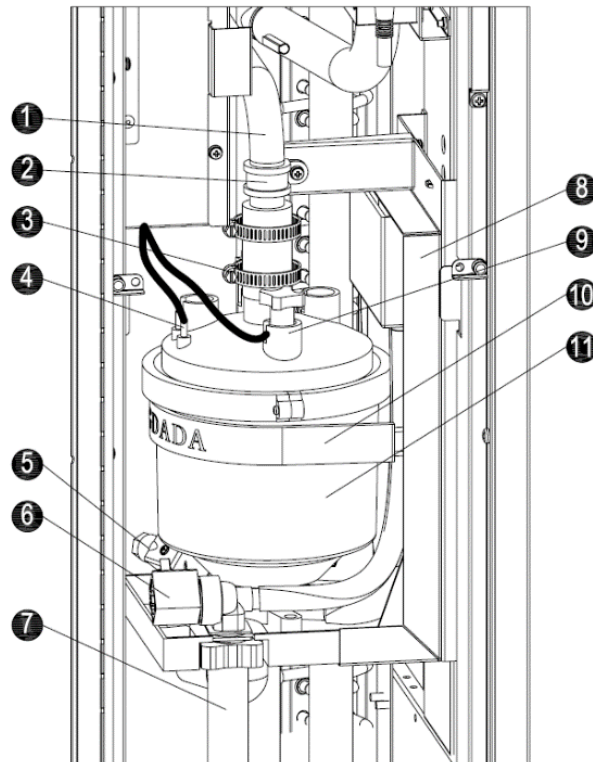

Item	Description	Item	Description
①	Humidification nozzle	⑦	Humidification water supply pipe
②	Nozzle fixing clamp	⑧	Humidifier base
③	Hose fixing clamp	⑨	Electrode pin
④	Humidification water level terminal	⑩	Humidification barrel locking belt
⑤	Drain solenoid valve	⑪	Humidification barrel
⑥	Water supply solenoid valve		

Removal of humidification barrel:

1. Set the unit to OFF state, open the rear door of the unit, pull out the electric control box and remove the cover of the electric control box;
2. Press the forced drainage rocker switch ① of the humidifier in the electric control box to ON to empty the water in the humidifying barrel;
3. Disconnect the power supply of the unit, and perform maintenance after the surface of the humidifying barrel cools down;
4. Remove the power cord from the electrode pin;

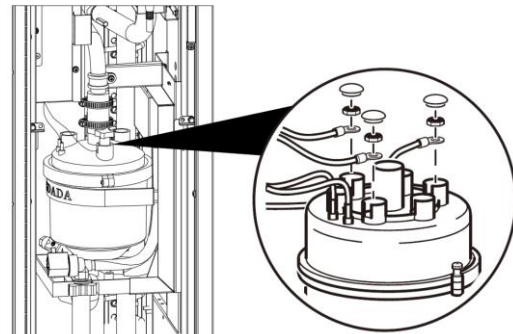
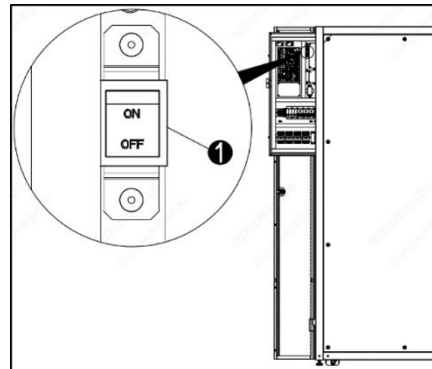

5. Loosen the nozzle fixing clamp and the hose fixing clamp to separate the hose from the humidification barrel;

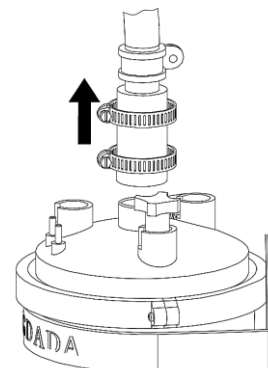

6. Loosen the humidification barrel locking belt;

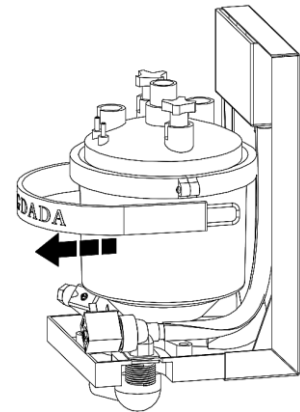

7. Lift the humidification barrel upwards to remove the humidifier from the base;

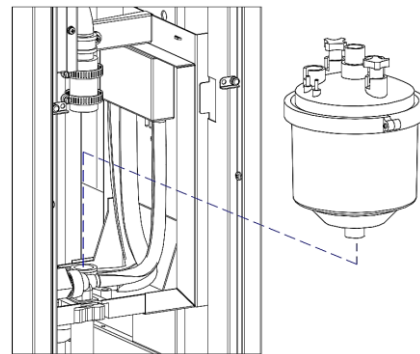

8. Install a new humidification barrel by reversing the removal steps.

Note: Before installing a new humidification barrel, clean the humidification water supply pipe and other parts to remove debris and sediment. See “Cleaning Humidifier Components” in the following section for complete instructions.

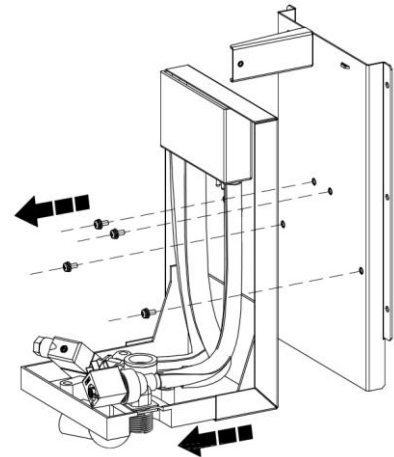

Remove the humidifier base assembly

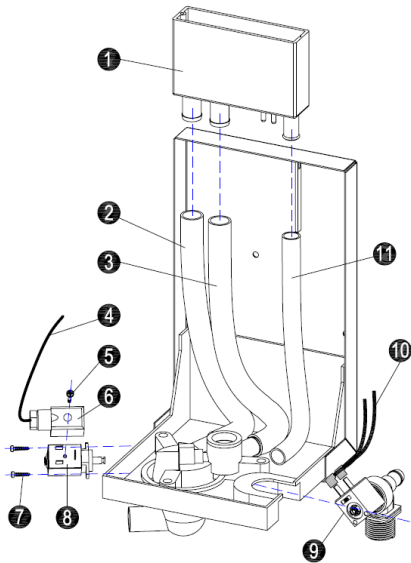

Item Description

- ① Watershed base
- ② Overflow pipe
- ③ Humidifying barrel
- ④ Drain valve wire
- ⑤ Drain valve coil fixing screw
- ⑥ Drain valve coil

Item Description

- ⑦ Drain valve fixing screw
- ⑧ Drain solenoid valve
- ⑨ Water make-up solenoid valve
- ⑩ Water make-up valve wire
- ⑪ Water injection pipe of watershed base

Clean the humidifier parts

During normal operation of the humidifier, deposits such as mineral particles will accumulate in the humidifier tank and other parts. These deposits must be removed regularly to ensure efficient operation of the humidifier. As the water quality varies from place to place, the cleaning time should be decided as appropriate. It is recommended to conduct monthly inspections (monthly cleaning if necessary), and clean with clean water and soft brush.

Note: Never use cleaners or solvents to clean the humidifier parts. In order to remove scale, use 20% vinegar solution and rinse with water.

Humidifier control panel

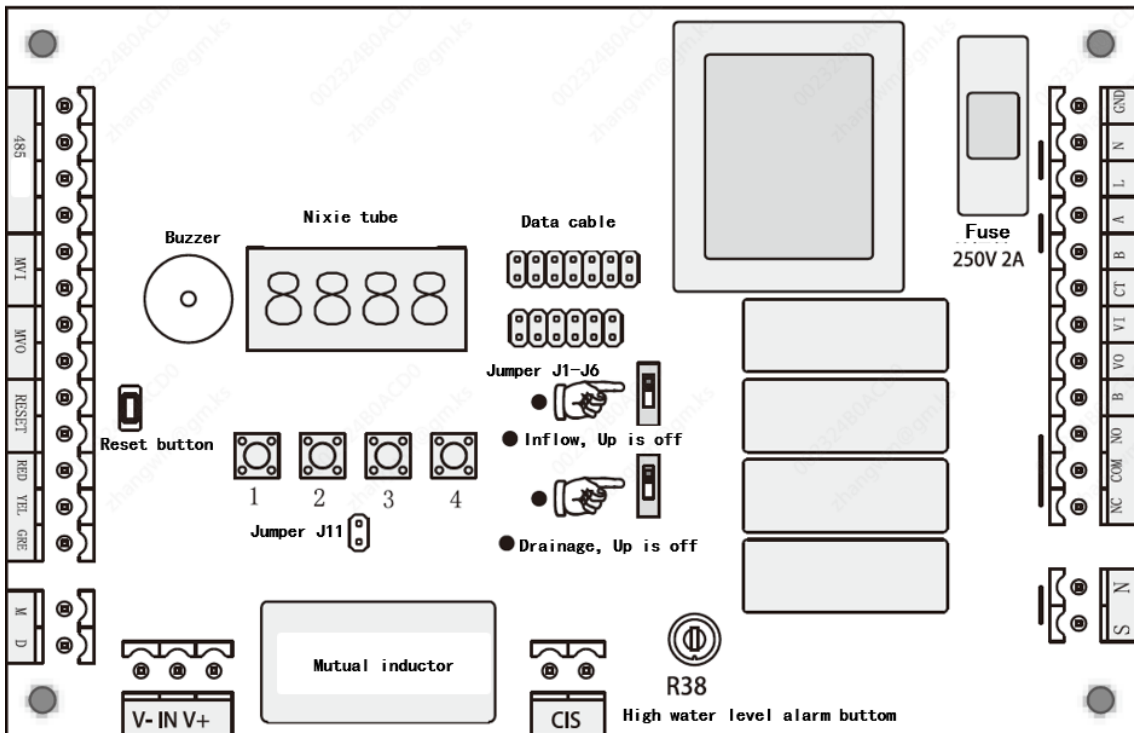

1. Indicator light

The green indicator light is on or flashing when the unit is powered on and working, the yellow one is on during automatic cleaning, and the red one is on or flashing when it alarms.

2. Nixie tube

The 4 nixie tubes are divided into two parts.

Nixie tubes 1 & 2: When alarming, the alarm state is displayed, such as E1. During normal operation, the 1# nixie tube displays the state of the humidifier (the upper, middle and lower horizontal bars respectively indicate water supply, humidification, and drainage), and the 2# tube is off.

Nixie tubes 3 & 4: Display working current in ampere. Even in the alarm state, 3# and 4# tubes will also display the current.

3. Alarm code

Fault code	Fault type
E1	High water level alarm state
E2	High current alarm state
E3	Low current alarm state (0.1A)
E4	Drain valve alarm state
E5	Maintenance status of humidifying barrel

4. Manual water supply/drainage operation

Stop manual water supply: Turn up the manual water supply switch DIP. Start manual water supply: Turn down the manual switch DIP.

Stop manual drainage (there is a separate rocker switch, which needs to be consistent with the DIP switch): Turn up the manual drainage switch DIP. Start manual drainage: Turn down the manual drainage switch DIP.

6.9 Refrigeration System Maintenance

The components of the refrigeration system must be inspected monthly to see if the system is functioning properly and whether there is any sign of wear. It is often accompanied by failures before the device fails or is damaged, and regular inspection is the main means to prevent most system failures. The refrigerant pipeline must have proper support, and it is not allowed to lean against the ceiling, floor or fixing frame. Check the refrigerant pipeline every six months to confirm whether there is wear or the existing fixing structure is loose.

When the system pipeline is equipped with a sight glass, the flow rate of the liquid refrigerant and the water content of the system can be observed through the sight glass. The background color of the sight glass can be used to judge whether the water content in the system exceeds the standard.

When the refrigeration system fails, the fault can be judged according to the running parameters of the system.

6.9.1 Suction pressure

When the suction pressure drops below the low pressure protection operating value, it may cause the compressor to

shut down. On the other hand, too high suction pressure will also reduce the cooling of the compressor motor by the refrigerant, which may cause damage to the compressor. The minimum (low pressure protection operating value) or the maximum (design operation) suction pressure value is shown in Table 6-9-1.

Table 6-9-1 Suction pressure

System	Minimum pressure kPa (PSIG) R410A	Maximum pressure kPa (PSIG) R410A
Air-cooled	650 (94)	1300 (188)

6.9.2 Exhaust pressure

The exhaust pressure may increase or decrease due to load conditions or condenser efficiency. When the exhaust pressure reaches the high-pressure protection operating value, the compressor will shut down for protection. See Table 6-9-2.

Table 6-9-2 Exhaust pressure

System design	kPa (PSIG)	System design	kPa (PSIG)
Air-cooled	2850 (413)	Maximum pressure	4000 (580)

6.9.3 Expansion valve

Operation

The automatic adjustment of the electronic expansion valve ensures that sufficient refrigerant is supplied to the evaporator to meet the needs of load conditions. Through the difference between the target exhaust temperature and the actual exhaust temperature, it is possible to check whether the expansion valve is operating normally.

Note

1. For systems equipped with electronic expansion valves, you only need to check whether the electronic expansion valve is operating, no manual adjustment is needed.

6.9.4 Air-cooled condenser

Routine maintenance:

Machine frame

1. Ensure that the connection to the ground is firm, and check at least once every six months;

Refrigerant pipeline

Check the refrigerant pipeline at least every month as follows:

1. Ensure that the pipeline is firm and reliable;
2. Ensure that all refrigerant pipelines are free from oil stains and frost.

Condenser

Check the condenser at least every month as follows:

1. Ensure that there is no damage to the fins such as reversed fins;

2. Clean the condenser fins;
3. Confirm that the air inlet and outlet of the condenser are smooth.

Fan

Check the fan at least every six months as follows:

1. Ensure that the junction box is not damaged or loose;
2. Ensure that there is no deformation, damage or interference in the fan grille and wind deflector;
3. Ensure that the fan has no abnormal noise, abnormal vibration, blade jamming, etc.

6.9.5 Replacement of compressor

Warning

When replacing the compressor, avoid skin contact with refrigerant and lubricating oil, or else it can cause severe burns or frostbite to the skin. Wear long-sleeved gloves when handling contaminated parts.

FocusAir series air conditioners use DC inverter compressors with high reliability. If the construction strictly follows the correct procedures, the probability of failure during operation is very low.

Compressor motor is rarely burned out due to insulation failure. In the event that the motor is actually burned out, it is often caused by poor mechanical or lubrication, i.e. overheating.

If the problems that may cause compressor failure can be detected and corrected early, most compressor failures can be avoided. Maintenance personnel shall regularly conduct maintenance and inspections for possible abnormal operation. Instead of replacing the compressor after a failure, it is better to take the necessary steps to ensure the normal operation of the system. This is not only easier but also much cheaper.

When diagnosing the compressor, check whether all the electrical components of the compressor are operating normally:

1. Check all fuses and circuit breakers;
2. Check the conditions of high and low pressure protection;
3. If the compressor fails, find out whether the failure is caused by an electrical failure or a mechanical failure.

Mechanical failure

Mechanical failure of the compressor can't be judged by smelling the burning smell. Try to rotate the motor. If a mechanical failure is confirmed, the compressor must be replaced. If the motor burns out, correct the factors that caused the motor burn out and clean the system. It should be noted that the burning of the compressor motor is usually caused by improper cleaning of the system.

Electrical failure

Electrical failure can be judged by the obvious pungent smell. If severe burn occurs, the lubricating oil will turn black and become acidic. In the event of electrical faults and refrigeration compressor motor completely burned out, measures must be

taken to clean the system to eliminate acidic substances in the system and prevent such failure from recurring in the future.

Note

Damage to the replaced parts caused by improper cleaning isn't covered by the warranty.

When the compressor is completely burned out, both the compressor and the dry filter should be replaced, and the expansion valve should be checked. If there is a failure, it should also be replaced. Before replacement, it is necessary to clean the system. If you don't know the cleaning method, please consult our professional technicians.

Steps to replace the compressor

1. Cut off the power supply;
2. Connect the low pressure and high pressure terminals of the pressure gauge to the needle valves on the suction and drain pipes for refrigerant recovery;
3. Remove the electrical connection with the compressor;
4. Remove the electric heating belt at the bottom of the compressor;
5. Weld the suction pipe and exhaust pipe of the unit;
6. Remove the faulty compressor;
7. If the compressor is completely burned out, clean the refrigeration system pipeline and replace the dry filter;

Note

Do not remove the rubber plugs of the suction and exhaust ports of the new compressor to be replaced prematurely. Do not leave it in the air for more than 15 minutes when the plug is removed in order to prevent the refrigerant oil of the compressor from bringing water into the system.

7. Install the new compressor in place, connect the pipeline, and connect the electrical circuit;
8. Vacuum the system and add refrigerant according to the requirements of the commissioning specification;
9. Follow the normal startup and commissioning process to power on the system and check whether the system operating parameters are normal. Observe the state of the refrigerant through the sight glass (if equipped), and determine the amount of refrigerant added in combination with the system pressure and temperature parameters until the system is operating normally.

Chapter 7 Troubleshooting

This chapter introduces fault diagnosis and processing, which can be used in conjunction with the alarm section.

⚠ Warning

1. Some circuits have lethal high voltages, and only professional technicians are allowed to perform maintenance operations on the unit. Special care must be taken when troubleshooting with power on.
2. When using the jumper for troubleshooting, always remember to remove the jumper after the repair work is completed. The connected jumpers left over may overrun the control function and cause damage to the equipment.

Refer to Table 7-1 to Table 7-5 for fault diagnosis and treatment of each component.

Table 7-1 Fan troubleshooting

Problem	Possible cause	Items to be checked or treatment method
Fan can't start	No main power	Check the rated voltage of L1, L2 and L3
	Circuit breaker has tripped or fuse has blown out	Check the fuse and circuit breaker of the main fan
	Overload, air-break switch tripped	Reset manually. Check the average current
	Control board failure	Check whether there is output from the control end of the motherboard according to the circuit diagram
	Fan fails	Replace the fan

Table 7-2 Compressor and refrigeration system troubleshooting

Problem	Possible cause	Items to be checked or treatment method
Compressor can't start	Power is not turned on (shut down)	Check the main power switch, fuse or circuit breaker and connecting wires
	Power overload, air-break switch tripped	Reset manually. Check the average current
	Circuit connection is loose	Fasten the circuit connector
	Compressor coil is short-circuited and burned	Check the motor, and replace it immediately if any defect is found
Compressor is not running and contactor is not closed	No cooling demand	Check controller status
	High pressure protection activated	Check high pressure switch and high pressure value
Contactor is closed and compressor does not run	Fuse has blown out or circuit breaker has tripped	Check the line voltage after checking the fuse or circuit breaker and contactor
	Built-in protector of compressor disconnected	Check whether the compressor coil is open. If yes, it will reset automatically after the coil cools down
Compressor stops after running for 5 minutes, and contactor is disconnected	Refrigerant leaks, low pressure protection activated	Check the suction pressure
Exhaust pressure is high	Condenser is dirty	Clean the condenser
	Condensing equipment does not operate; check	Check operation steps

Problem	Possible cause	Items to be checked or treatment method
	water system)	
	Excessive refrigerant charge	Check if the degree of subcooling is too high
Exhaust pressure is low	Refrigerant leaks	Check for leaks, repair and add refrigerant
	The outdoor fan speed controller has failure, the output voltage is always full load voltage and does not change with the change of condensing pressure	Replace the speed controller immediately if any defect is found
No change in suction and exhaust pressure after starting	Compressor reversal or internal air blistering	If the compressor is reversed, exchange any two L lines of the compressor; if there is internal air blistering, replace the compressor
Suction pressure is low or liquid flows back	Insufficient refrigerant in the system	Check for leaks, repair and add refrigerant
	Air filter is dirty	Replace the filter
	Dry filter is clogged	Replace the filter
	Improper regulation of superheat	Adjust in strict accordance with the adjustment steps of the expansion valve
	Expansion valve sensing element is defective	Replace the expansion valve
	Poor air distribution	Check the air supply and return air system
	Condensing pressure is too low	Check condenser failure
Compressor noise is too loud	Lubricating oil loss causes bearing wear	Add lubricating oil
	Compressor or pipeline is loose	Fasten the fixing clip
Compressor overheating	Compression ratio is too high	Check the setting of high pressure and low pressure protection value, and check whether the condenser is blocked
		Check whether all evaporator and condenser fans are operating normally
	Suction temperature is too high	Adjust expansion valve or add proper amount of refrigerant

Table 7-3 Dehumidification system troubleshooting

Problem	Possible cause	Items to be checked or treatment method
No dehumidification effect	The control system does not require the dehumidification function	Check control system state
	Compressor contactor can't be closed	Refer to Table 7-2
	The compressor does not operate, the fuse has blown out or the circuit breaker has tripped	Refer to Table 7-2 Check the fuse or circuit breaker and its contacts, check the line voltage

Table 7-4 Humidifier troubleshooting

Problem	Possible cause	Items to be checked or treatment method
No humidification	Not filled with water	Check water source

effect		Check whether the water filling solenoid valve is working
		Check if the water inlet pipe is blocked
		Humidification pump has failure
	No need for humidification	Check controller state

Table 7-5 Heating system troubleshooting

Problem	Possible cause	Items to be checked or treatment method
The heating system does not operate, and the contactor does not engage	The heating start condition is not reached	Check the state of the controller
Display heating, but electric heater does not generate heat	The electric heater wiring terminal is loose	Check whether the terminal is inserted tightly
The contactor is closed but there is no heating effect	The heater is burned out	Cut off the power and check the resistance of the heater with an ohmmeter

Attached Table 1 Maintenance and Inspection Items (Monthly)

Date: _____

Prepared by: _____

Device model: _____

Serial number: _____

Filter

- ___ 1. Check whether the filter is damaged or blocked
- ___ 2. Check the filter blockage switch
- ___ 3. Clean the filter

Fan part

- ___ 1. Whether the fan impeller is deformed

Compressor part

- ___ 1. Check for leaks
- ___ 2. Listen to the running sound and observe the running vibration

Air-cooled condenser (if used)

- ___ 1. Cleanliness of condenser fins
- ___ 2. Whether the fan installation base is firm
- ___ 3. Whether the fan cushion is aging or damaged
- ___ 4. Whether the lightning protection board is still effective (if equipped. It is best to check once a week in thunderstorm seasons)
- ___ 5. The refrigerant pipeline is properly supported

Refrigeration cycle system

- ___ 1. Check the suction pressure
- ___ 2. Check the exhaust pressure
- ___ 3. Check the refrigerant pipeline
- ___ 4. Check the moisture content of the system (observe through sight glass)
- ___ 5. Check the hydraulic bypass valve
- ___ 6. Check the thermal expansion valve

Heating system

- ___ 1. Check the operation of the reheat system components
- ___ 2. Check the corrosion of components

Wet film humidifier

- ___ 1. Check if the drain of the water pan is blocked
- ___ 2. Check the humidification and water supply solenoid valve
- ___ 3. Check the humidification pump
- ___ 4. Check the water quality

Signature _____ Note: Please copy this form for archiving.

Attached Table 2 Maintenance and Inspection Items (Semi-annual)

Date: _____

Prepared by: _____

Device model: _____

Serial number: _____

Filter

- ___ 1. Check whether the filter is damaged or blocked
- ___ 2. Check the filter blockage switch
- ___ 3. Clean the filter

Fan part

- ___ 1. Whether the fan impeller is deformed
- ___ 2. Whether the bearing is worn or not
- ___ 3. Check and tighten the circuit connectors

Compressor part

- ___ 1. Check for leaks
- ___ 2. Listen to the running sound and observe the running vibration
- ___ 3. Check and tighten the circuit connectors

Air-cooled condenser

- ___ 1. Cleanliness of condenser fins
- ___ 2. Whether the fan installation base is firm
- ___ 3. Whether the fan cushion is aging or damaged
- ___ 4. Whether the lightning protection board is still effective (if equipped. It is best to check once a week in thunderstorm seasons)
- ___ 5. Voltage regulation function of speed controller
- ___ 6. The temperature switch is at the specified setting value
- ___ 7. The refrigerant pipeline is properly supported
- ___ 8. Check and tighten the circuit connectors

Refrigeration cycle system

- ___ 1. Check the suction pressure and suction superheat

- ___ 2. Check the exhaust pressure and condensation supercool

- ___ 3. Check the refrigerant pipeline
- ___ 4. Check the moisture content of the system (observe through sight glass)

- ___ 5. Check the electronic expansion valve

- ___ 6. Check the hydraulic bypass valve

- ___ 7. Check if there is need to add refrigerant (observe through sight glass)

Heating system

- ___ 1. Check the operation of the reheat system components

- ___ 2. Check the corrosion of components

- ___ 3. Check and tighten the circuit connectors

Humidifier

- ___ 1. Check if the drain of the water pan is blocked

- ___ 2. Check the water injection valve and drain valve of the humidifier

- ___ 3. Check the mineral deposits in the water pan

- ___ 4. Check the water quality

- ___ 5. Check the humidification pump

Electrical control part

- ___ 1. Check the fuse and air-break switch

- ___ 2. Check and tighten the circuit connectors

- ___ 3. Check the control program

- ___ 4. Check the pull-in condition of the contactor

Signature _____ Note: Please copy this form for archiving.

Appendix 1 Identification of Toxic and Hazardous Substances or Elements

Part name	Toxic and hazardous substances or elements					
	Lead	Mercury	Cadmium	Hexavalent chromium	Polybrominated biphenyls	Polybrominated diphenyl ethers
	Pb	Hg	Cd	Cr6+	PBB	PBDE
Cabinet	×	○	○	○	○	○
Refrigeration accessories	×	○	○	○	○	○
Fan unit	×	○	×	○	○	○
Heating unit	×	○	○	○	○	○
Electric control unit	×	○	×	○	○	○
Display	×	×	○	○	○	○
Manufactured board	×	○	○	○	○	○
Heat exchanger	×	○	○	○	○	○
Copper pipes	×	○	○	○	○	○
Cables	×	○	○	○	○	○
<p>○: Indicates that the content of the toxic and hazardous substance in all homogeneous materials of the part is below the limit requirement in SJ/T-11363-2006;</p> <p>×: Indicates that the content of the toxic and hazardous substance in at least one of the homogeneous materials of the part exceeds the limit requirement of SJ/T11363-2006</p>						
<p>1. The reasons for the lead content of the above components: the copper alloy of the parts contains lead; the high temperature solder contains lead; the high temperature solder in the diode contains lead; the resistor glass uranium contains lead (exempt); the electronic ceramic contains lead (exempt);</p> <p>2. The switch contacts of the power distribution part contains cadmium and its compounds</p>						
<p>Note on the environment-friendly use period (EFUP): The EFUP of this product (marked on the product) refers to the period during which the contained toxic and hazardous substances or elements will not have a serious impact on the environment, people and property product from the production date (except the battery) under normal use conditions and compliance with the safety precautions of this product.</p>						
<p>Scope of application: FOCUSAIR air conditioners</p>						

Note: The content of this information is for reference only, and isn't a legal basis for any offer or speculation; without the written consent of the company, any unit or individual may not extract or copy part or all of the content of this manual or spread in any form. The product is subject to change without prior notice. The official offer and the actual product shall prevail when purchasing; the company reserves the right of final interpretation of this information.

FS025/30/40/50/60/70 (600 wide) wiring diagram:

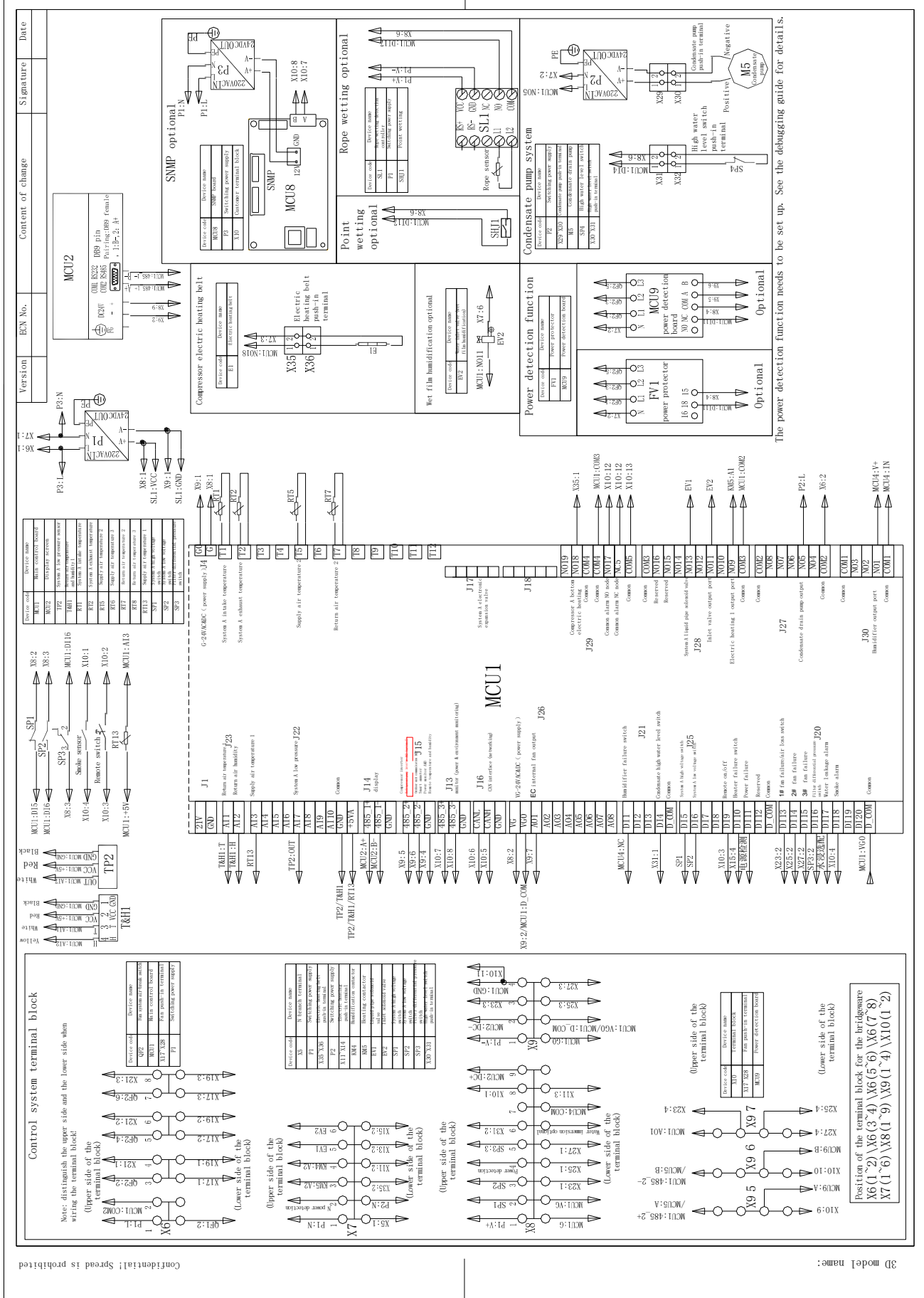

Note: The optional function part is wired according to the function configuration of the whole machine system.

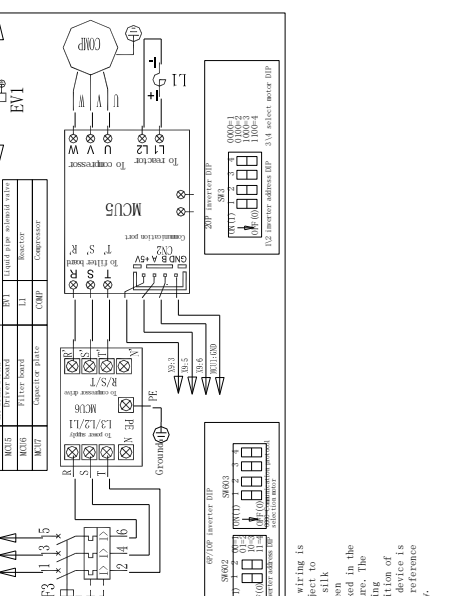
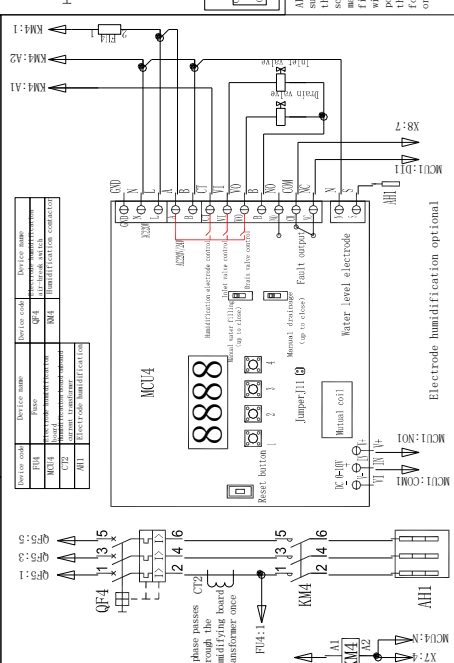
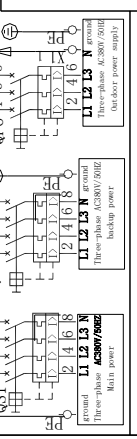
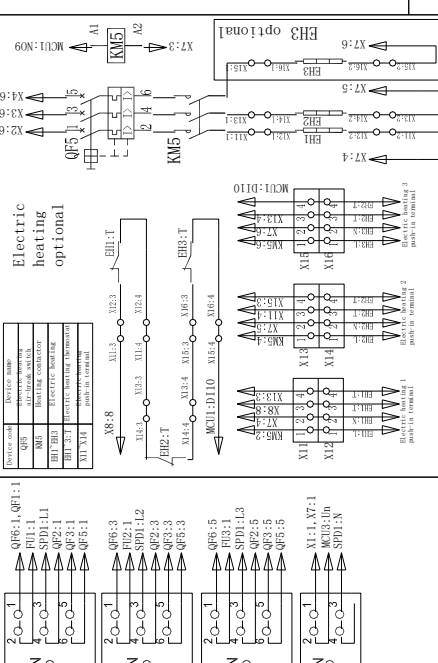
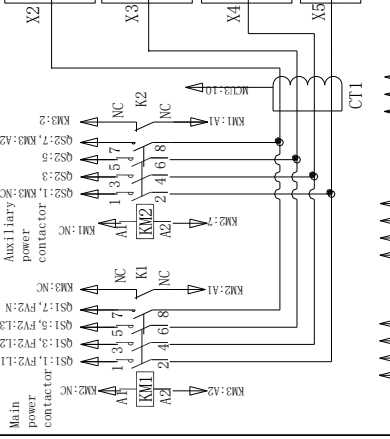
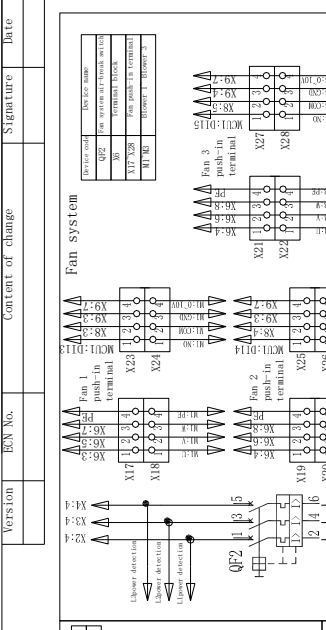
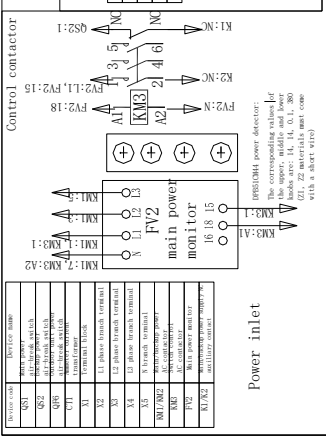

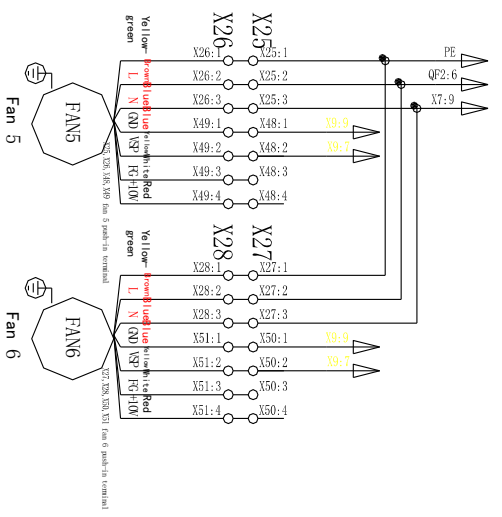
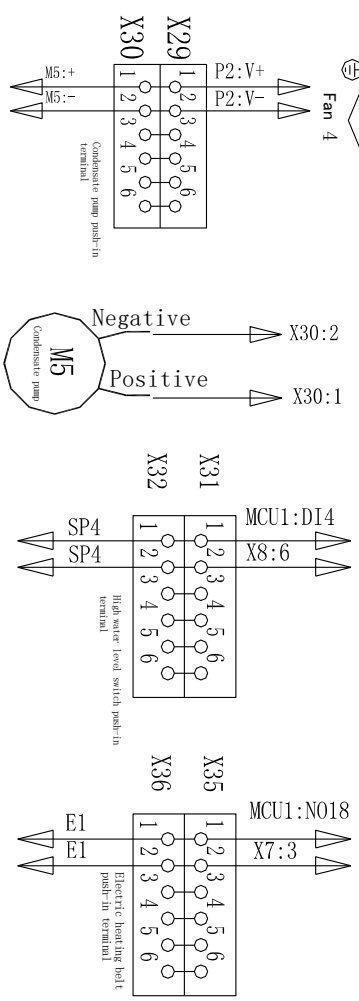
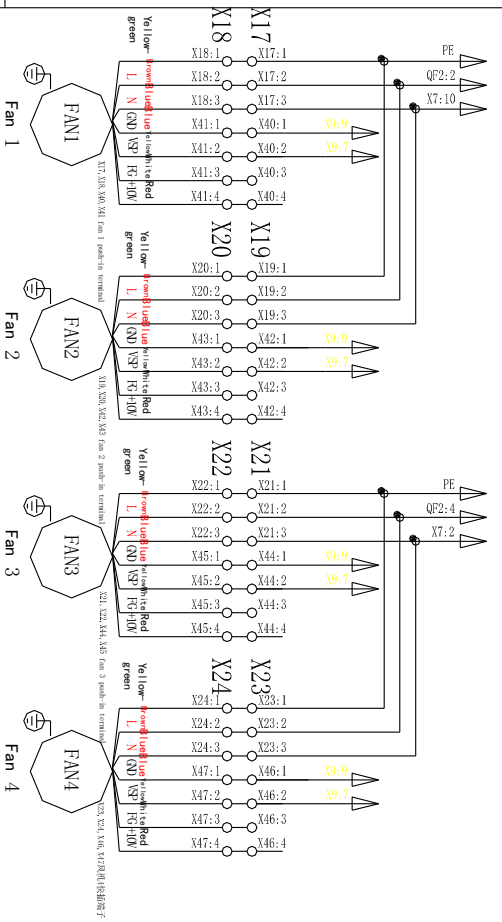
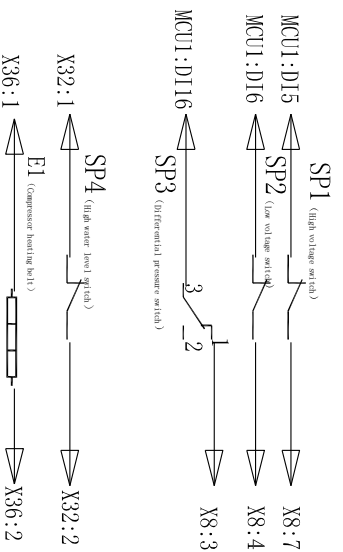

Pin	Signal Name	Description
J1-1	24VDC	Power supply (+24VDC)
J1-2	GND	Power supply ground
J1-3	RT1	System A indoor temperature sensor
J1-4	RT2	System B indoor temperature sensor
J1-5	RT3	System A outdoor temperature sensor
J1-6	RT4	System B outdoor temperature sensor
J1-7	RT5	System A return air temperature sensor
J1-8	RT6	System B return air temperature sensor
J1-9	RT7	System A humidity sensor
J1-10	RT8	System B humidity sensor
J1-11	RT9	System A high pressure sensor
J1-12	RT10	System B high pressure sensor
J1-13	RT11	System A low pressure sensor
J1-14	RT12	System B low pressure sensor
J1-15	RT13	System A fan failure sensor
J1-16	RT14	System B fan failure sensor
J1-17	RT15	System A condensation sensor
J1-18	RT16	System B condensation sensor
J1-19	RT17	System A inlet water temperature sensor
J1-20	RT18	System B inlet water temperature sensor
J1-21	RT19	System A outlet water temperature sensor
J1-22	RT20	System B outlet water temperature sensor
J1-23	RT21	System A hot water temperature sensor
J1-24	RT22	System B hot water temperature sensor
J1-25	RT23	System A cold water temperature sensor
J1-26	RT24	System B cold water temperature sensor
J1-27	RT25	System A hot water flow sensor
J1-28	RT26	System B hot water flow sensor
J1-29	RT27	System A cold water flow sensor
J1-30	RT28	System B cold water flow sensor
J1-31	RT29	System A hot water valve
J1-32	RT30	System B hot water valve
J1-33	RT31	System A cold water valve
J1-34	RT32	System B cold water valve
J1-35	RT33	System A hot water pressure
J1-36	RT34	System B hot water pressure
J1-37	RT35	System A cold water pressure
J1-38	RT36	System B cold water pressure
J1-39	RT37	System A hot water flow
J1-40	RT38	System B hot water flow
J1-41	RT39	System A cold water flow
J1-42	RT40	System B cold water flow
J1-43	RT41	System A hot water valve
J1-44	RT42	System B hot water valve
J1-45	RT43	System A cold water valve
J1-46	RT44	System B cold water valve
J1-47	RT45	System A hot water pressure
J1-48	RT46	System B hot water pressure
J1-49	RT47	System A cold water pressure
J1-50	RT48	System B cold water pressure
J1-51	RT49	System A hot water flow
J1-52	RT50	System B hot water flow
J1-53	RT51	System A cold water flow
J1-54	RT52	System B cold water flow
J1-55	RT53	System A hot water valve
J1-56	RT54	System B hot water valve
J1-57	RT55	System A cold water valve
J1-58	RT56	System B cold water valve
J1-59	RT57	System A hot water pressure
J1-60	RT58	System B hot water pressure
J1-61	RT59	System A cold water pressure
J1-62	RT60	System B cold water pressure
J1-63	RT61	System A hot water flow
J1-64	RT62	System B hot water flow
J1-65	RT63	System A cold water flow
J1-66	RT64	System B cold water flow
J1-67	RT65	System A hot water valve
J1-68	RT66	System B hot water valve
J1-69	RT67	System A cold water valve
J1-70	RT68	System B cold water valve
J1-71	RT69	System A hot water pressure
J1-72	RT70	System B hot water pressure
J1-73	RT71	System A cold water pressure
J1-74	RT72	System B cold water pressure
J1-75	RT73	System A hot water flow
J1-76	RT74	System B hot water flow
J1-77	RT75	System A cold water flow
J1-78	RT76	System B cold water flow
J1-79	RT77	System A hot water valve
J1-80	RT78	System B hot water valve
J1-81	RT79	System A cold water valve
J1-82	RT80	System B cold water valve
J1-83	RT81	System A hot water pressure
J1-84	RT82	System B hot water pressure
J1-85	RT83	System A cold water pressure
J1-86	RT84	System B cold water pressure
J1-87	RT85	System A hot water flow
J1-88	RT86	System B hot water flow
J1-89	RT87	System A cold water flow
J1-90	RT88	System B cold water flow
J1-91	RT89	System A hot water valve
J1-92	RT90	System B hot water valve
J1-93	RT91	System A cold water valve
J1-94	RT92	System B cold water valve
J1-95	RT93	System A hot water pressure
J1-96	RT94	System B hot water pressure
J1-97	RT95	System A cold water pressure
J1-98	RT96	System B cold water pressure
J1-99	RT97	System A hot water flow
J1-100	RT98	System B hot water flow
J1-101	RT99	System A cold water flow
J1-102	RT100	System B cold water flow
J1-103	RT101	System A hot water valve
J1-104	RT102	System B hot water valve
J1-105	RT103	System A cold water valve
J1-106	RT104	System B cold water valve
J1-107	RT105	System A hot water pressure
J1-108	RT106	System B hot water pressure
J1-109	RT107	System A cold water pressure
J1-110	RT108	System B cold water pressure
J1-111	RT109	System A hot water flow
J1-112	RT110	System B hot water flow
J1-113	RT111	System A cold water flow
J1-114	RT112	System B cold water flow
J1-115	RT113	System A hot water valve
J1-116	RT114	System B hot water valve
J1-117	RT115	System A cold water valve
J1-118	RT116	System B cold water valve
J1-119	RT117	System A hot water pressure
J1-120	RT118	System B hot water pressure
J1-121	RT119	System A cold water pressure
J1-122	RT120	System B cold water pressure
J1-123	RT121	System A hot water flow
J1-124	RT122	System B hot water flow
J1-125	RT123	System A cold water flow
J1-126	RT124	System B cold water flow
J1-127	RT125	System A hot water valve
J1-128	RT126	System B hot water valve
J1-129	RT127	System A cold water valve
J1-130	RT128	System B cold water valve
J1-131	RT129	System A hot water pressure
J1-132	RT130	System B hot water pressure
J1-133	RT131	System A cold water pressure
J1-134	RT132	System B cold water pressure
J1-135	RT133	System A hot water flow
J1-136	RT134	System B hot water flow
J1-137	RT135	System A cold water flow
J1-138	RT136	System B cold water flow
J1-139	RT137	System A hot water valve
J1-140	RT138	System B hot water valve
J1-141	RT139	System A cold water valve
J1-142	RT140	System B cold water valve
J1-143	RT141	System A hot water pressure
J1-144	RT142	System B hot water pressure
J1-145	RT143	System A cold water pressure
J1-146	RT144	System B cold water pressure
J1-147	RT145	System A hot water flow
J1-148	RT146	System B hot water flow
J1-149	RT147	System A cold water flow
J1-150	RT148	System B cold water flow
J1-151	RT149	System A hot water valve
J1-152	RT150	System B hot water valve
J1-153	RT151	System A cold water valve
J1-154	RT152	System B cold water valve
J1-155	RT153	System A hot water pressure
J1-156	RT154	System B hot water pressure
J1-157	RT155	System A cold water pressure
J1-158	RT156	System B cold water pressure
J1-159	RT157	System A hot water flow
J1-160	RT158	System B hot water flow
J1-161	RT159	System A cold water flow
J1-162	RT160	System B cold water flow
J1-163	RT161	System A hot water valve
J1-164	RT162	System B hot water valve
J1-165	RT163	System A cold water valve
J1-166	RT164	System B cold water valve
J1-167	RT165	System A hot water pressure
J1-168	RT166	System B hot water pressure
J1-169	RT167	System A cold water pressure
J1-170	RT168	System B cold water pressure
J1-171	RT169	System A hot water flow
J1-172	RT170	System B hot water flow
J1-173	RT171	System A cold water flow
J1-174	RT172	System B cold water flow
J1-175	RT173	System A hot water valve
J1-176	RT174	System B hot water valve
J1-177	RT175	System A cold water valve
J1-178	RT176	System B cold water valve
J1-179	RT177	System A hot water pressure
J1-180	RT178	System B hot water pressure
J1-181	RT179	System A cold water pressure
J1-182	RT180	System B cold water pressure
J1-183	RT181	System A hot water flow
J1-184	RT182	System B hot water flow
J1-185	RT183	System A cold water flow
J1-186	RT184	System B cold water flow
J1-187	RT185	System A hot water valve
J1-188	RT186	System B hot water valve
J1-189	RT187	System A cold water valve
J1-190	RT188	System B cold water valve
J1-191	RT189	System A hot water pressure
J1-192	RT190	System B hot water pressure
J1-193	RT191	System A cold water pressure
J1-194	RT192	System B cold water pressure
J1-195	RT193	System A hot water flow
J1-196	RT194	System B hot water flow
J1-197	RT195	System A cold water flow
J1-198	RT196	System B cold water flow
J1-199	RT197	System A hot water valve
J1-200	RT198	System B hot water valve
J1-201	RT199	System A cold water valve
J1-202	RT200	System B cold water valve
J1-203	RT201	System A hot water pressure
J1-204	RT202	System B hot water pressure
J1-205	RT203	System A cold water pressure
J1-206	RT204	System B cold water pressure
J1-207	RT205	System A hot water flow
J1-208	RT206	System B hot water flow
J1-209	RT207	System A cold water flow
J1-210	RT208	System B cold water flow
J1-211	RT209	System A hot water valve
J1-212	RT210	System B hot water valve
J1-213	RT211	System A cold water valve
J1-214	RT212	System B cold water valve
J1-215	RT213	System A hot water pressure
J1-216	RT214	System B hot water pressure
J1-217	RT215	System A cold water pressure
J1-218	RT216	System B cold water pressure
J1-219	RT217	System A hot water flow
J1-220	RT218	System B hot water flow
J1-221	RT219	System A cold water flow
J1-222	RT220	System B cold water flow
J1-223	RT221	System A hot water valve
J1-224	RT222	System B hot water valve
J1-225	RT223	System A cold water valve
J1-226	RT224	System B cold water valve
J1-227	RT225	System A hot water pressure
J1-228	RT226	System B hot water pressure
J1-229	RT227	System A cold water pressure
J1-230	RT228	System B cold water pressure
J1-231	RT229	System A hot water flow
J1-232	RT230	System B hot water flow
J1-233	RT231	System A cold water flow
J1-234	RT232	System B cold water flow
J1-235	RT233	System A hot water valve
J1-236	RT234	System B hot water valve
J1-237	RT235	System A cold water valve
J1-238	RT236	System B cold water valve
J1-239	RT237	System A hot water pressure
J1-240	RT238	System B hot water pressure
J1-241	RT239	System A cold water pressure
J1-242	RT240	System B cold water pressure
J1-243	RT241	System A hot water flow
J1-244	RT242	System B hot water flow
J1-245	RT243	System A cold water flow
J1-246	RT244	System B cold water flow
J1-247	RT245	System A hot water valve
J1-248	RT246	System B hot water valve
J1-249	RT247	System A cold water valve
J1-250	RT248	System B cold water valve

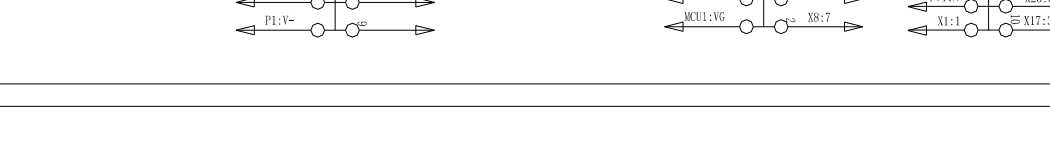
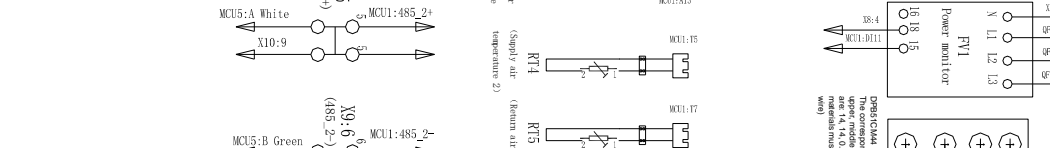
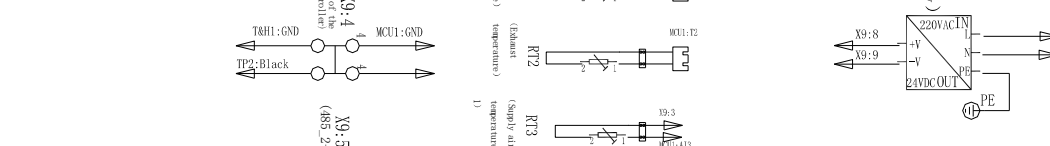
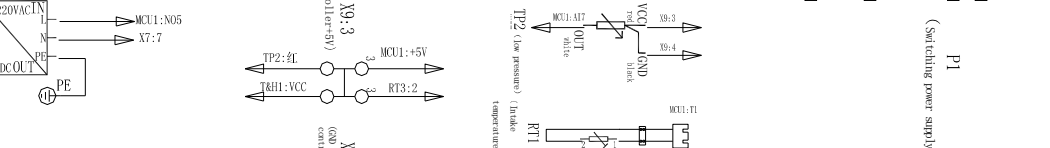
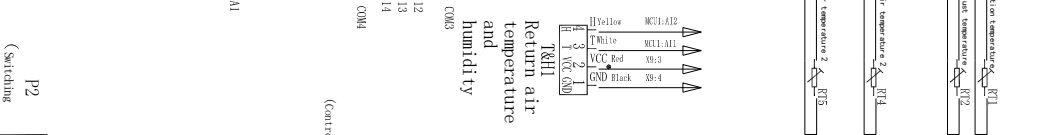
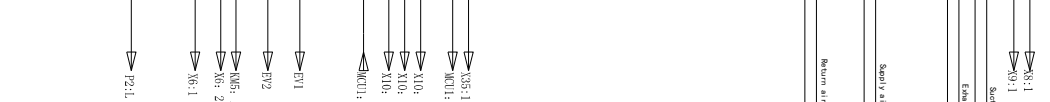

Main power supply				
PE	L1	L2	L3	N

Backup power supply				
PE	L1	L2	L3	N

Outdoor power supply				
L1	L2	L3	N	PE

COM		Group		Outdoor unit		Common	
COM	Staked	central	Low level	A	B	NO	NC
COM	COM	H	L	A	B	COM	COM

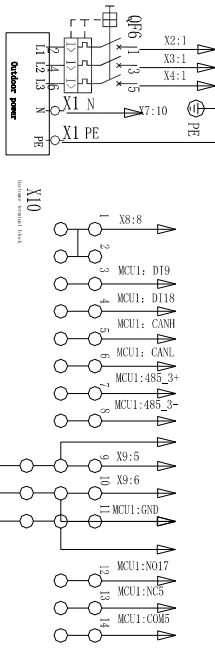

Customer terminal block
