



- Data Center Integrated Solution -

Kstar Precision Air Conditioner Series

Founded in 1993, Shenzhen KSTAR Science & Technology Co., Ltd (Stock Code: 002518) is a National Torch Plan Key High-tech Enterprise, and also a pioneer of UPS industry and a total solution provider for Data Center Critical Infrastructure & Photovoltaic Inverter Systems in Mainland China. KSTAR is fully committed to the R&D and has been providing high-quality products with full service to over 150 countries and regions worldwide, leading the industrial development with innovation.



ISO9001



ISO14001

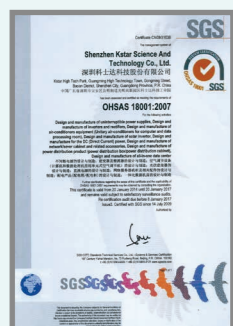

OHSAS18001



IECQ QC080000

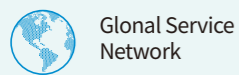

Global Service Network



7 × 24 Response and Support



31 Domestic Service Centers
172 Domestic Service Stations



National Customer Service Hotline:
400-700-9662



17 Overseas Technical Service Centers
40 Overseas Service Engineers

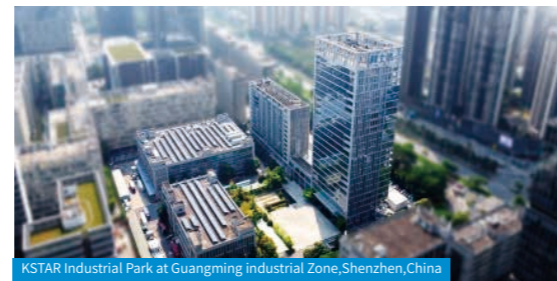

KSTAR Industrial Park at Guangming Industrial Zone, Shenzhen, China



KSTAR Industrial Park at Zhongkai Hi-Tech Zone, Huizhou, China



KSTAR Industrial Park at Guanlan Fuyuan industrial Zone, Shenzhen, China



KSTAR headquarters Software Park, Keji C.Rd.2nd, Hi-Tech Industrial Zone, Shenzhen, China



CATL-KSTAR SCIENCE & TECHNOLOGY CO., LTD.



Jiangxi Changxin Golden Sunshine Power Supply Co. LTD.

MatrixAir™ Series Precision Air Conditioner	03
Product Presentation	03
Technical Parameters	14



StationAir™ Series Precision Air Conditioner	16
Product Presentation	16
Technical Parameters	19



FocusAir™ Series Precision Air Conditioner	20
Product Presentation	20
Technical Parameters	26



InsertAir™ Series Rack-mounted Precision Air Conditioner	28
Product Presentation	28
Technical Parameters	29



Refrigerant Pump Assisted Free Cooling Energy-saving Series Precision Air Conditioner	30
Product Presentation	30
Technical Parameters	33



KC Series Flat Plate Outdoor Unit	34
KC Series Centralized Outdoor Unit	36
Precision Air Conditioner Customization Solution	38
Qualification Certification	40



How to achieve better precision cooling of data center?

Kstar MatrixAir™ Series Precision Air Conditioner, provides you with perfect solution.

Reliability · High Efficiency · Environmentally Friendly · Flexibility

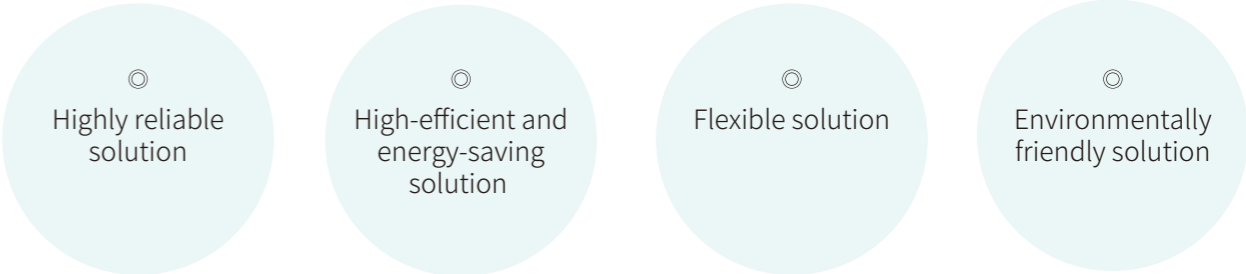

- Severe test
- Well designed cooling system
- High-quality components
- Advanced and reliable intelligent control system
- High-efficient configuration
- Accurate refrigerant flow regulation
- Intelligent humidification control
- Electronic expansion valve
- EC fan
- Adjustable heating capacity
- Personalized and customized design
- Wide range cooling capacity
- Modular structure design
- Seven cooling types
- Refrigerant:R410A

High Reliability

Kstar's MatrixAir™ series precision air conditioner integrates advanced energy-saving and environmentally friendly technology in the industry, relies on comprehensive development tools and technical resources and is carefully designed according to high standards. It can ensure the high reliability of unit with high-quality system design. It is a new generation of advanced, reliable, high-efficient, energy-saving, safe and environmentally friendly products in key cooling industry. It can guarantee the continuous, high-efficient and reliable operation of the key IT equipment of the data center 24 hours of 365 days in the whole year.

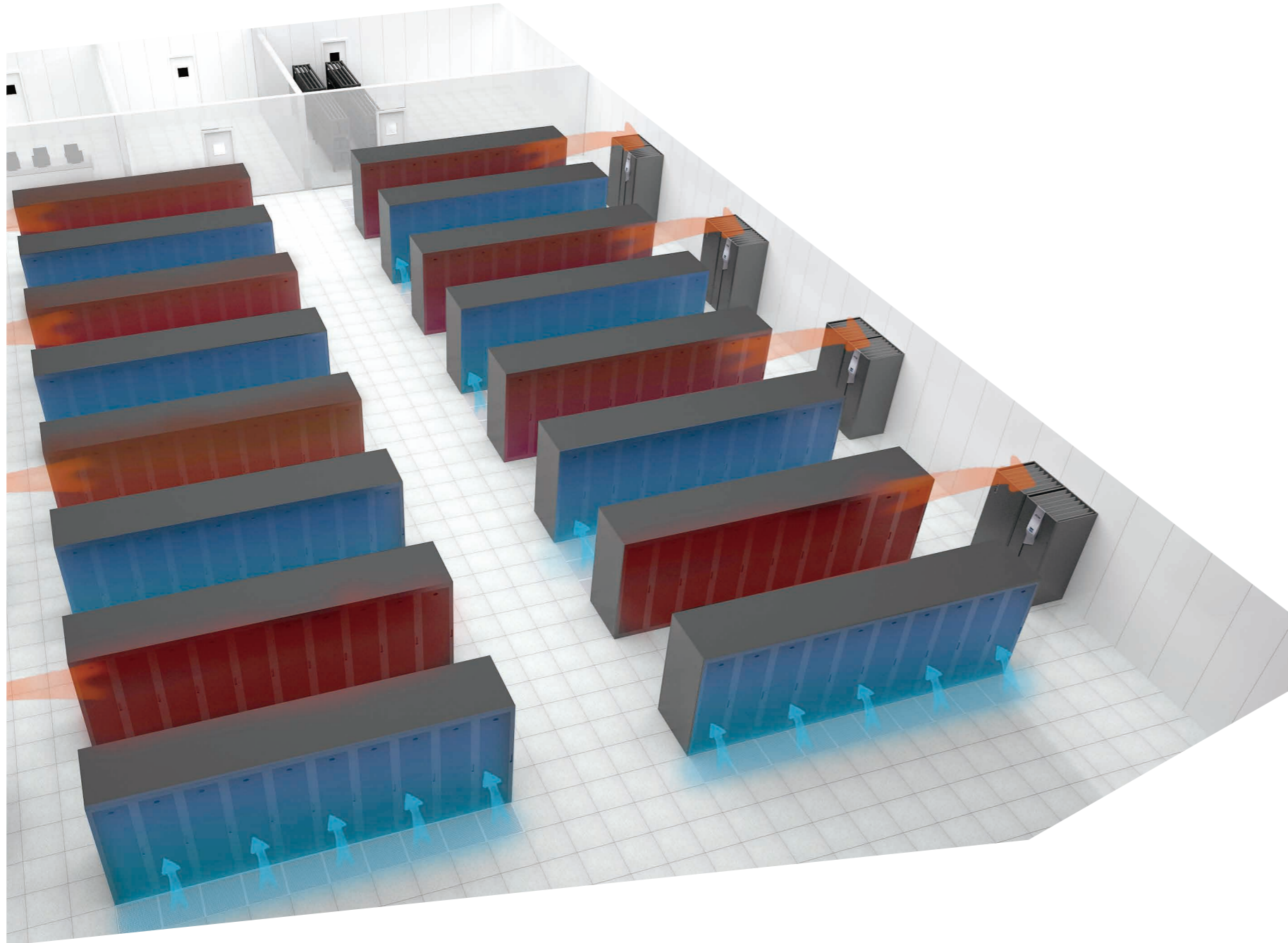

Severe Test Verification

MatrixAir™ series precision air conditioner has undergone the comprehensive and severe test in Kstar's performance test laboratory to ensure that the unit can still run reliably under harsh conditions.

Well designed cooling system

Higher heat exchange efficiency, more stable and reliable flow control, more reliable air distribution and layout, can realize the high energy efficiency and high reliability of MatrixAir™.

High-quality Components

MatrixAir™ adopts high-quality components that have been strictly designed and selected. Compressor, fan, valve, electrical system and heating and humidification system components are recognized brands in the industry. High-quality components can ensure the high reliability and ultra-long life of air conditioner system.





◎ Advanced and Reliable Intelligent Control System

MatrixAir™ adopts powerful professional precision air conditioner intelligent control system to realize high-efficient, energy-saving, stable and reliable control of the unit with superior performance.

- Standard RS485 intelligent communication interface, SNMP card optional
- Graphical state display and temperature & humidity curve display
- Alarm notification and it can record more than 3000 alarm events
- Display and setting of environmental parameters
- Reminding of running time and maintenance of main components
- Multi-level password protection
- Auto restart when mains recovers
- 7 inches color touch screen is standard equipment, friendly interface, simple operation



High Efficiency & Energy Saving

Energy saving comes from efficiency, and high which requires intelligent coordination. MatrixAir™ series precision air conditioner system consists of high-efficiency components and intelligent control system that can quickly and accurately adjust the output. It can intelligently coordinate all outputs, achieve better efficiency and realized more energy-saving operation.

High-efficiency Configuration

High-efficiency EC Fan

Compared with belt-driven frontward centrifugal fan, backward centrifugal fan means lower power consumption, less maintenance and better air distribution, which can improve cooling efficiency; EC fan with efficiency up to 90% will provide a wide range of air volume regulation and lower energy consumption.



High-efficiency Scroll Compressor

Its excellent quality guarantees the high efficiency, high reliability, low noise and ultra-long life of the unit.



High-efficiency Heating System

High-efficiency heater has high thermal density, compact structure, fast and stable heating, low surface temperature and long service life; It has different power level for heating and it can select proper heating power according to real-time environment and easily maintain accurate environment.



Electronic Expansion Valve

The electronic expansion valve controlled by microcomputer can accurately control the refrigerant flow in the system and realize the improvement of unit start-up features, fast and stable working condition control and better refrigeration performance; Relying on the wide flow characteristics of electronic expansion valve, the air conditioner system can make full use of the lower external ambient temperature and save energy consumption up to 30%.



High-efficiency Humidification System

It is equipped with intelligent humidification control system and washable humidifying barrel. Humidification capacity is adjustable, and support automatic water drainage and flushing. It is suitable for different water quality. It is energy-saving and water-saving, safe and aseptic.



Intelligent Humidification Control

Air conditioner system can respond quickly to output requirements; Humidification capacity is adjustable.

Dynamic Airflow

EC fan can respond quickly to output requirements; EC fan can save up to 30% energy than conventional AC fans.

Adjustable heating power

Adjustable heating power can make it intelligently choose heating power level according to real-time environment and easily maintain accurate environment.

High-efficiency Flow Control

The valve can accurately and quickly make the output suitable for various states and improve the performance and efficiency of air conditioner system; The electronic expansion valve controlled by microcomputer can save energy consumption up to 30%.

Flexibility

Seven cooling types, Up-flow type and down-flow type, wide cooling range and personalized and customized design are available for Kstar MatrixAir™ series precision air conditioner system, which can flexibly meet different needs of users.

Modular Components with High Adaptability

Kstar MatrixAir™ series precision air conditioner is composed of high-quality modular components that can be flexibly applied and applicable to different needs of data center.

- Fan component
- Humidification component
- Expansion valve component
- Heating component
- Cooling component

.....

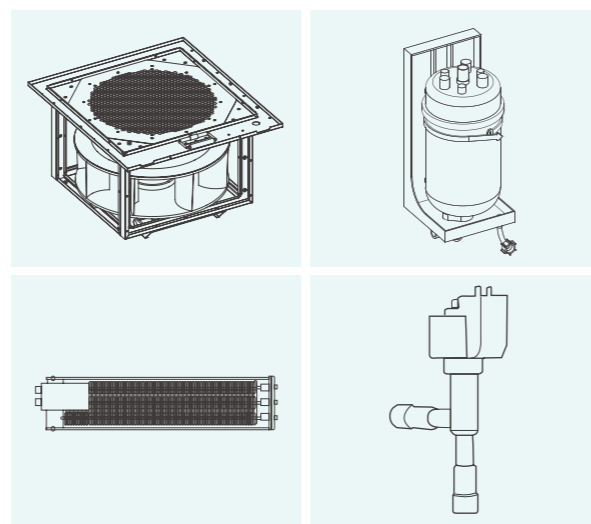

Plenum	Large-power heater	DC inverter compressor
External remote temperature & humidity sensor	Level G4 high-efficiency filter	Low temperature kits
Floor Stand	Water leakage detection system	High static pressure

Rich and Flexibly-matched Options

Kstar's professional engineers can flexibly combine a refrigeration solution that accurately matches the project from multiple options according to the needs of users.



Flexible Expansion Capacity

Kstar MatrixAir™ series precision air conditioner adopts modular structure, and each unit has an independent intelligent control system, which supports network group control of multiple units and can be flexibly arranged in a centralized or decentralized mode so as to meet the expansibility demand of growing data center on cooling capacity.

Wide Cooling Range

The cooling capacity range provided by Kstar MatrixAir™ series precision air conditioner is 25kW-300kW, which can fully meet the requirements of data center on refrigeration level.

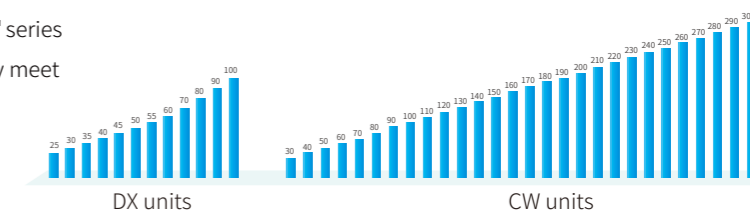

Modular Structure Design

Kstar MatrixAir™ series precision air conditioner adopts modular structure design, with more compact unit structure and smaller footprint; moreover, it supports modular split and solves the difficult problem in the handling and maintenance of compact space. Full frontal maintenance is available, and lateral and rear parts can also be opened for maintenance.

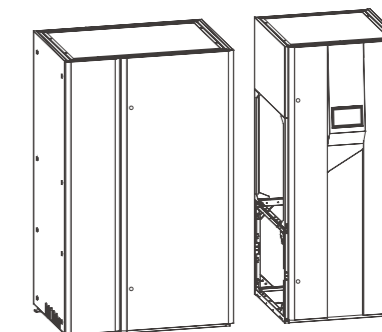

Seven Cooling Types

Seven kinds of cooling systems are optional for Kstar MatrixAir™ series precision air conditioner, including ① Air-cooled type (A), ② water-cooled type(w), ③ chilled water type (C), ④ glycol(water) free cooling (G), ⑤ air-cooled double cooling source type (D), ⑥ water-cooled double cooling source ⑦ double chilled water type. They can meet different needs of users.

The dual cooling system of Kstar MatrixAir™ series precision air conditioner is designed, with better redundancy and strong ability to cope with faults.

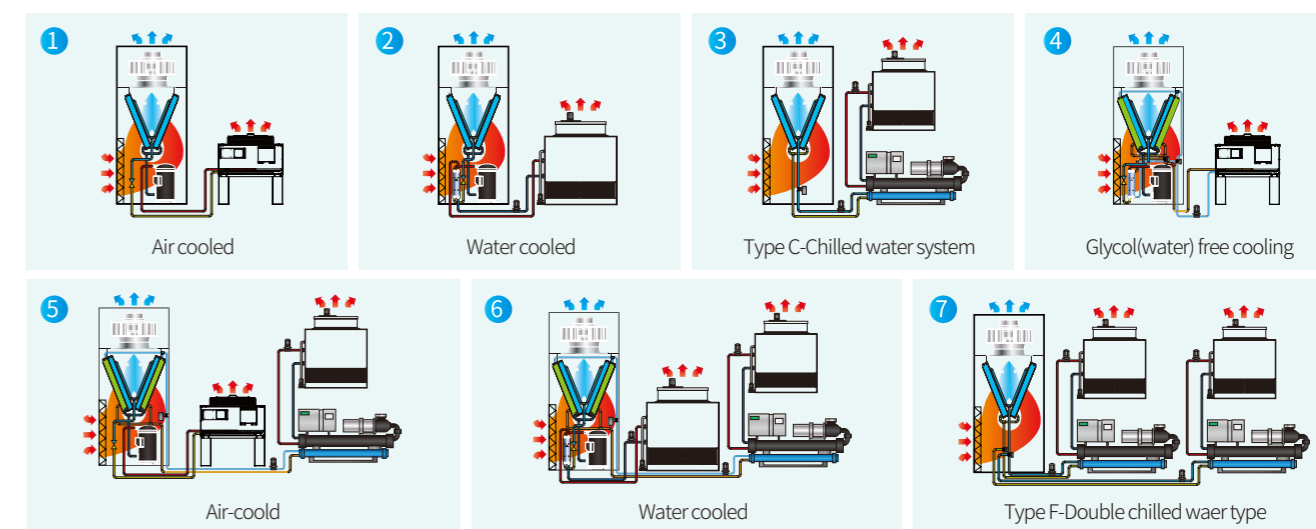

Technical Parameters



▼DX Unit (Air-cooled Type)

MT****	Unit	025	030	035	040 (Single)	045 (Single)	050 (Single)	040 (Dual)	050 (Dual)	060	070	080	090	100
Total cooling capacity ¹⁾	kW	26.9	32.7	37.2	41.8	45.9	51.7	42.6	52.8	61.7	71.1	81.8	92.1	101.3
Sensible capacity ¹⁾	kW	25.0	31.4	35.0	39.7	44.1	49.6	40.5	49.6	59.2	66.1	78.5	86.6	94.2
Air volume	m ³ /h	7800	8600	9500	12000	13000	13500	12500	13500	18700	19300	21600	24000	26000
Sensible heat ratio (SHR)	%	93	96	94	95	96	96	95	94	96	93	96	94	93
Heating capacity	kW	6	6	6	9	9	9	9	9	9	9	12	12	12
Number of compressors	PCS	1	1	1	1	1	1	2	2	2	2	2	2	2
Humidifying capacity	kg/h	6	8	8	10	10	10	10	10	10	10	12	12	12
Number of fan	pcs	1	1	1	1	1	1	1	1	2	2	2	2	2
Fan type	/	EC												
Full load current	A	28.8	32.7	35.1	42.2	48.3	52.1	43.8	53.6	58.7	63.5	76.3	81.7	96.6
Unit weight	kg	275	350	360	380	400	410	470	490	660	670	680	720	730
Unit width	mm	850	928	928	928	928	928	1378	1378	1828	1828	1828	1828	1828
Unit depth	mm	850	995	995	995	995	995	995	995	995	995	995	995	995
Unit height	mm	1960	1975	1975	1975	1975	1975	1975	1975	1975	1975	1975	1975	1975

▼CW Unit (Chilled Water Type)

MT****	Unit	030	040	050	060	070	080	090	100	110	120
Total cooling capacity ²⁾	kW	30.0	40.0	50.0	60.0	70.0	80.0	90	100.0	110.0	120.0
Sensible capacity ²⁾	kW	27.0	36.0	45.0	64.0	66.0	72.0	81	91.0	101.4	108.0
Air volume	m ³ /h	9500	10400	12800	13900	15000	19500	20500	21700	22900	24000
Water flow	m ³ /h	5.8	7.8	8.9	11.2	12.9	15.0	17.2	18.6	19.8	22.6
Water pressure drop	kPa	45	50	60	60	65	70	70	62	68	72
Heating capacity	kW	6	6	6	6	6	12	12	12	12	12
Humidifying capacity	kg/h	4.5	4.5	4.5	4.5	4.5	9	9	9	9	9
Number of fan	pcs	1	1	1	1	1	2	2	2	2	2
Fan type	/	EC fan									
Full load current (Cooling only)	A	18	18	18	18	18	36	36	36	36	36
Full load current (Constant temperature and humidity)	A	6	6	6	6	6	12	12	12	12	12
Inlet and outlet pipe diameter	mm	G1	G1-1/2	G1-1/2	G1-1/2	G1-1/2	G1-1/2	G1-1/2	G2	G2	G2
Unit weight	kg	340	350	360	450	460	535	540	560	570	580
Unit width	mm	928	928	928	1128	1128	1828	1828	1828	1828	1828
Unit depth	mm	995	995	995	995	995	995	995	995	995	995
Unit height	mm	1975	1975	1975	1975	1975	1975	1975	1975	1975	1975

Technical Parameters

▼CW Unit (Chilled Water Type)

MT****	Unit	130	140	150	160	170	180	190	200	250
Total cooling capacity ²⁾	kW	130.0	140.0	150.0	160.0	170.0	180.0	190.0	200.0	250.0
Sensible capacity ²⁾	kW	117.0	126.0	135.0	144.0	153.0	162.0	171.0	180.0	225.0
Air volume	m³/h	26200	27800	29500	32000	34000	36200	38400	41000	48000
Water flow	m³/h	25.1	27.1	27.9	30.5	31.3	33.9	35.7	37.8	43.0
Water pressure drop	kPa	77	82	85	90	95	100	110	110	135
Heating capacity	kW	12	12	12	12	12	12	12	12	12
Humidifying capacity	kg/h	9	9	9	9	9	9	9	9	12
Number of fan	pcs	2	2	2	3	3	3	3	3	4
Fan type	/	EC fan								
Full load current (Cooling only)	A	36	36	36	42	42	42	42	42	50
Full load current (Constant temperature and humidity)	A	12	12	12	18	18	18	18	18	24
Inlet and outlet pipe diameter	mm	G2	G2	G2	G2	G2	G2	G2	G2	DN65 Flange
Unit weight	kg	620	630	640	720	730	740	750	760	1150
Unit width	mm	2228	2228	2228	2728	2728	2728	2728	2728	3828
Unit depth	mm	995	995	995	995	995	995	995	995	995
Unit height	mm	1975	1975	1975	1975	1975	1975	1975	1975	1975

Notes:

1.Parameter table

1) Air/water cooled unit data is based on indoor return air temperature 24°C and 50%RH, outdoor ambient temperature 35°C;

2) Chilled water unit data is based on indoor return air temperature 24°C and 50%RH, chilled water in/out temperature 7°C/12°C.

2. Shenzhen Kstar Science & Technology Co., Ltd. reserves the right of final interpretation of the data without prior notice if the data in the table is changed due to technical progress of the product.

StationAir™ Series Precision Air Conditioner



Small and Medium Data Center Room High-efficiency Precision Cooling

Kstar StationAir™ Series Precision Air Conditioner, provides you with perfect solution.

Kstar StationAir™ series precision air conditioner is equipped with constant temperature and humidity function, and it adopts the design of large air volume and high sensible heat ratio (SHR) to meet the needs of professional computer room; The precisely matched high-efficiency cooling system is designed for all-weather operation in full 24 hours of 365 days and is equipped with large-area evaporator to ensure the optimal energy-saving operation of the unit all the time.



High-efficient and Reliable Cooling Solution

Energy saving

- High energy efficiency ratio (EER): Perfectly-matched cooling system ensures super high energy efficiency ratio
- High heat sensible ratio (HSR): The unit adopts the design of large air volume and small enthalpy difference to ensure high heat sensible ratio
- Green refrigerant: Standard R410a green refrigerant, and R407C and R22 refrigerants optional

High Reliability

- The high-efficient and stable compressor and backward centrifugal fan with famous brands are adopted to guarantee the long service life and high energy efficiency ratio of the unit
- High-quality components of industry recognized brands are adopted to ensure the high reliability of the unit
- The product has undergone strict and rigorous test and inspection

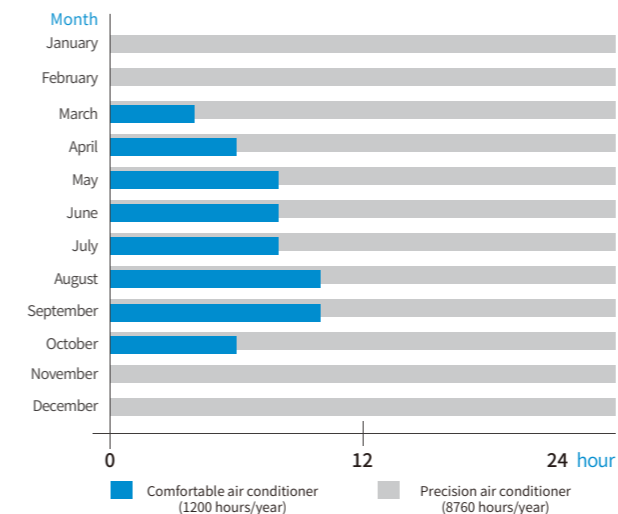

All-weather Operation Design

- Precision air conditioner unit is designed in accordance with the principle of all-weather ceaseless high-efficient and reliable operation for 24 hours of 365 days
- The unit is suitable for severe cold regions and can still run reliably at the low temperature of -40°C after the selection of low temperature kits
- Stepless speed regulation outdoor fan can adapt to outdoor environmental temperature change
- Electronic expansion valve ensures system can response to the changing working condition quickly

Intelligent Controller

- Precise microcomputer control system, large-screen display, with multi-level password protection and experts fault diagnosis function
- Equipped with the standard RS485 communication interface and supported the remote monitoring
- Wide input voltage design, with self-recovery function after power resume, lack phase protection, fault phase protection and over or low voltage protection function is optional to ensure the unit uninterrupted working
- It can flexibly switch from the main unit to the backup unit automatically to achieve the automatic switch and rotation

Flexible Application

- Precision air conditioner unit is flexibly selected and matched according to the project to meet different needs of users
- Configuration of unit model at or below 12kW: Quick connector
- Various air supply types: upflow, downflow, front-flow and underflow
- Various cooling types: Air-cooled type, water-cooled type, chilled water type, ethylene glycol-cooled type and double cooling source type
- Rich options: EC fan, high-efficiency filter and special humidifier, etc
- Customization solution: High/low temperature environment solution, low noise solution, high altitude pressure of unit, and long connecting pipe/high drop solution
- Compact structure, small footprint, 100% front maintenance

Scope of Application

- Small and medium-sized computer room
- Equipment room and power house
- Outdoor electronic and communication equipment room
- Transformer substation
- Laboratory, testing room and storage room
- Computer room in commercial buildings



Technical Parameters

DX Unit (Air-cooled Type)

ST***	Unit	005			007			012			017			020		
Unit configuration	-	Single cooling	Constant temperature	Constant temperature and humidity	Single cooling	Constant temperature	Constant temperature and humidity	Single cooling	Constant temperature	Constant temperature and humidity	Single cooling	Constant temperature	Constant temperature and humidity	Single cooling	Constant temperature	Constant temperature and humidity
Total cooling capacity ¹⁾	kW		5.5			7.5			12.5			17.5			20.5	
Sensible capacity ²⁾	kW		5.2			6.8			11.3			15.8			18.6	
Air volume	m ³ /h		2000			2250			2850			5000			6200	
Sensible heat ratio (SHR)	/		0.95			0.91			0.90			0.90			0.91	
Heating capacity	kW	-	3	3	-	3	3	-	4	4	-	6	6	-	6	6
Humidifying capacity	kg/h	-	-	2.5	-	-	2.5	-	-	4	-	-	4.5	-	-	4.5
Number of compressor	pcs		1			1			1			1			1	
Number of fan	pcs		1			1			1			1			1	
Voltage	Vdc	220~240	220~240	380~415	220~240	220~240	380~415	380~415	380~415	380~415	380~415	380~415	380~415	380~415	380~415	380~415
Frequency	Hz	50	50	50	50	50	50	50	50	50	50	50	50	50	50	50
Phase	P	1	1	3	1	1	3	3	3	3	3	3	3	3	3	3
Full load current	A	11.6	26.2	15.5	15.3	29.9	19.2	11.3	18.6	18.6	16	28.2	28.2	17	29.2	29.2
Unit weight	kg	105	110	120	115	120	130	165	170	180	265	270	280	285	290	300
Unit width	mm		550			550			650			750			750	
Unit depth	mm		450			450			550			700			700	
Unit height	mm		1750			1750			1850			1900			1900	

Supporting Outdoor unit

KCS***	Unit	007		010		018		024		028	
Heat exchange capacity	kW		7.6		10.4		18.1		23.8		27.2
Full load current	A		0.5		0.7		1.4		2.7		2.7
Unit weight	kg		38		48		60		117		124
Unit width	mm		898		935		981		1400		1400
Unit depth	mm		340		422		440		975		975
Unit height	mm		606		807		1256		651		651
Foot stool Height	mm		-		-		-		455		455

Notes:

- Parameter table
- 1) Data above is based on indoor return air temperature 24°C and 50%RH, outdoor ambient temperature 35°C.
- 2) ST005, ST007 and ST012 are pre-filled with refrigerant and equipped with 5m pipeline and outdoor unit mounting bracket.
- 3) Shenzhen Kstar Science & Technology Co., Ltd. reserves the right of final interpretation of the data without prior notice if the data in the table is changed due to technical progress of the product.

FocusAir™ Series Precision Air Conditioner



Data Center Inrow High-efficiency Precision Cooling Solution

Kstar FocusAir™ Series Precision Air Conditioner, provides you with perfect solution.

- Kstar StationAir™ series precision air conditioner is elaborately designed for the specific cooling needs of the new generation of high heat density data center cabinet
- The design is close to heat source application. It adopts brand-new airflow distribution method and serves the data center with high reliability, high efficiency, energy saving, accurate measurability and flexibility
- It solves intractable problems in practice with technologies such as real-time monitoring, dynamic coordinated output, cabinet size design and no need for raised floor to ensure the uninterrupted, high-efficient and reliable operation of key equipment for 24 hours of 365 days



FocusAir™ Series Precision Air Conditioner

◎ Accurate and Measurable Cooling

FocusAir™ series Inrow precision air conditioner directly deals with the hot air discharged from the server, shortens airflow path, prevents cold and hot air from mixing together, minimizes airflow loss and eliminates the uncertainty of airflow and cooling through the design of closeness to hot source. Through real-time monitoring on heat source load change and accurate adjustment of cooling capacity output and fan output, the cooling capacity and air volume can be accurate and predictable so that more targeted accurate cooling can be achieved and the problem of high-density heat dissipation of data center can be perfectly solved.



◎ Inrow Cooling Features

▼ More Reasonable and Accurate Air Distribution

FocusAir™ series can accurately predict airflow path, and the generated airflow is reasonably distributed in the inlet of front door of the cabinet so that cold airflow can be delivered to the desired place precisely; Moreover, the unit adopts EC stepless speed regulation DC fan and air volume automatically matches the load change of the server.

- Reasonable and accurate airflow control can minimize the loss of cooling capacity and make the planning of cooling system more reasonable
- Unique air distribution naturally achieves the containment effect of cold aisle



▼ Real-time Monitoring of the Heat Load

FocusAir™ series unit is compatible with multiple temperature sensors, monitoring the heat load change real-time, and directly control the supply air temperature (the inlet air temperature of servers), that is safe, reliable, and energy saving, making sure that the inlet air temperature of servers conform to the requirements and the equipment running in the best state.

▼ Flexibility and Compatibility of the Space Application

FocusAir™ series unit is compatible with main manufacturers' racks, suitable for concrete or raised floor room. Rack size modular frame, 4 air supply types, 3 cooling types. Flexible to expand as business grows.

▼ Dynamic Coordination Output

The IT equipments of data center run all year around, and the operation condition is constantly changing. The FocusAir refrigeration system works based on the change of the heat load, dynamic coordinates cooling capacity output and air volume output of the unit, realizes real-time matching with the load change to keep the unit running in the best condition.

▼ Precise Air Volume Control

FocusAir™ series units are standard with the EC fan that can rapidly response to the output requirements; the effect of energy saving in the part load mode is remarkable, up to 30% higher than the conventional AC fan.

▼ Stepless Speed Regulation Compressor

FocusAir™ series unit adopts DC variable frequency stepless speed regulation compressor, which can accurately control cooling capacity output by regulating the rotational speed of compressor, match the heat load change of heat source in real time, and achieve accurate cooling and high energy efficient operation.



◎ Inrow Cooling Features

▼ Electronic Expansion Valve

The electronic expansion valve controlled by microcomputer can quickly and accurately control the refrigerant flow in the system with the change of cooling demand. It can always ensure the high reliability and high energy efficiency of air conditioner system and realize the improvement of unit start-up features, fast and stable working condition control and better refrigeration performance; Relying on the wide flow characteristics of electronic expansion valve, the air conditioner system can make full use of the lower external ambient temperature and save energy consumption up to 30%.



◎ Advanced Functional Design



High Return Air Temperature Design

FocusAir™ series are designed in 100% sensible heat ration with the high return air temperature and it makes the data center operating in the state of more energy saving.



Multiple Sets of Temperature Sensor

Compatible with multiple sets of temperature sensor, real-time monitoring the heat load changes of the cabinet, accurate judging for refrigeration output.



G4 Filtrating System

The G4 filter system of FocusAir™ series with the filter jamming switch is safe and reliable.



Water Leaking Detection System

Equipped with the water leaking detection system can avoid the water leakage and make the system reliability.



Monitoring

Communication monitoring can monitor the unit status, manage and control the data center in a better way.



Rack Size Design, Compatible with the IT Environment

The compact design and compatibility conforming to different manufacturer make the FocusAir™ series unit suitable for different data centers.



No Need Raised Floor

The unique style of the FocusAir™ series is the ideal choice for the data center without the raised floor.



Humidifying/Heating System

It can deal with the temperature and humidity of the equipment room without the room level humidifying.



Cold Aisle Containment Effect

Without adding additional air restraint accessory, the unique airflow design has realized the effect of Cold Aisle Containment.



Avoiding the Water Leakage Trouble

Equipped with the condensing water pump, avoid the water leakage hidden trouble and make the system reliability.

FocusAir™ Series Unit Configuration

Advanced Intelligent Controller

FocusAir™ series adopts powerful professional precision air conditioner intelligent control system to realize high-efficient, energy-saving, stable and reliable control of the unit with superior performance.

- Standard RS485 intelligent communication interface
- Graphical state display and temperature & humidity curve display
- Alarm notification and it can record more than 3000 alarm events

- Display and setting of environmental parameters
- Reminding of running time and maintenance of main components
- Optional external remote temperature & humidity sensor
- Optional water leakage detector
- Optional condenser pump

Multiple Sets of Temperature Sensors

They monitor regional environment in real time, and the fan is adjusted according to temperature requirements in real time; The rotational speed of compressor or chilled water valve opening is adjusted in real time according to temperature requirements.

Convenient Installation and Maintenance

- Maintenance can be carried out from the front and rear parts
- Pipeline can be connected from bottom and top.

Three Cooling Types

Three kinds of cooling systems are available (A air-cooled type, W water-cooled type and C chilled water type).

Four Kinds of Air Supply Modes

FocusAir™ series can provide four different air supply options, including bilateral air supply, air supply on the right side, air supply on the left side, and forward air supply.

Cooling Configuration of Compressor

- DC variable frequency compressor
- EC fan
- Electronic expansion valve
- Intelligent controller
- Air filter
- High-efficiency heat exchanger
- Optional humidifier
- Optional heater

Cooling Configuration of Chilled Water

- EC fan
- Intelligent controller
- Air filter
- High-efficiency heat exchanger
- Two-way valve (Optional three-way valve)
- Optional humidifier
- Optional heater



FocusAir™ Series Precision Air Conditioner

Technical Parameters

DX Unit (Air-cooled Type)

FS***	Unit	007		012	
The unit configuration	/	Constant temperature	Constant temperature and humidity	Constant temperature	Constant temperature and humidity
Total cooling capacity ¹⁾	kW	7.5	7.5	12.5	12.5
Sensible capacity ¹⁾	kW	7.5	7.5	12.5	12.5
Air volume	m ³ /h	2500	2500	3000	3000
Sensible heat ratio	%	100	100	100	100
Heating capacity	kW	3	3	3.5	3.5
Humidifying capacity	kg/h	2.5	2.5	2.5	2.5
Number of compressors	PCS	1	1	1	1
Humidification	/	/	Electrode humidifier	/	Wet-film humidifier
Voltage	V	220±10%	380±10%	380±10%	380±10%
Frequency	Hz	50	50	50	50
Number of phase	p	1	3	3	3
Full load current	A	29.5	18.1	23.9	23.9
Unit weight	kg	220	225	220	230
Unit width	mm	300	300	300	300
Unit depth	mm	1200/1400	1200/1400	1200/1400	1200/1400
Unit height	mm	2000	2000	2000	2000

DX Unit (Air-cooled Type)

FS***	Unit	025	025	030	030	040	050	060	070
Refrigerant Type	-	R410A							
Total cooling capacity ¹⁾	KW	25.5	25.5	30.5	30.5	42.8	52.0	65.0	70.0
Sensible capacity ¹⁾	KW	25.5	25.5	30.5	30.5	42.8	52.0	65.0	70.0
Air volume	m ³ /h	5050	7000	5050	8000	9500	11000	12500	14200
Heating capacity	kW	3.5	3.5	3.5	6.0	6.0	9.0	9.0	9.0
Humidifying capacity	kg/h	2.5	2.5	2.5	3.5	3.5	3.5	3.5	3.5
Number of compressors	pcs	1	1	1	1	1	1	1	1
Number of fans	pcs	6	2	6	2	3	3	3	3
Voltage	V	380	380	380	380	380	380	380	380
Frequency	Hz	50	50	50	50	50	50	50	50
Full load current (Cooling only)	A	20.0	20.0	30.0	30.0	32.0	35.0	46.0	50.0
Full load current (Constant temperature and humidity)	A	30.0	30.0	36.5	36.5	38.5	46.0	55.0	60.0
Number of phase	p	3	3	3	3	3	3	3	3
Unit weight	kg	230	265	240	290	290	345	360	375
Unit width	mm	300	600	300	600	600	600	600	600
Unit depth	mm	1100/1200	1100/1200	1100/1200	1100/1200	1100/1200	1100/1200	1100/1200	1200
Unit height	mm	2000/2200	2000/2200	2000/2200	2000/2200	2000/2200	2000/2200	2000/2200	2200

▼ CW Unit (Chilled Water Type)

FS***	Unit	025	030	040	050	065
Total cooling capacity ²⁾	kW	25.1	30.5	40.5	50.2	67
Sensible capacity ²⁾	kW	25.1	30.5	40.5	50.2	67
Air volume	m ³ /h	5100	5500	9500	11000	12500
Water flow	m ³ /h	4.8	5.8	7.8	8.9	12.0
Water pressure drop	kPa	80	80	80	80	80
Heating capacity	kW	3	3	6	6	6
Humidifying capacity ³⁾	kg/h	2.5	2.5	3.5	3.5	3.5
Voltage	V	380	380	380	380	380
Frequency	Hz	50 / 60	50 / 60	50 / 60	50 / 60	50 / 60
Phase	P	3	3	3	3	3
Fan type	/	EC fan				
Full load current (Cooling only)	A	4.2	4.2	6.0	6.0	6.0
Full load current (Constant temperature and humidity)	A	12.0	12.0	18.9	18.9	18.9
Inlet and outlet pipe diameter	mm	G1	G1	G1-1/2	G1-1/2	G1-1/2
Unit weight	kg	190	210	230	260	275
Unit width	mm	300	300/600	600	600	600
Unit depth ⁴⁾	mm	1100/1200	1100/1200	1100/1200	1100/1200	1100/1200
Unit height	mm	2000	2000	2000	2000	2000

Notes:

- Parameter table
- Air/water cooled unit data is based on indoor return air temperature 37°C and 25%RH, outdoor ambient temperature 35°C;
- Chilled water unit data is based on indoor return air temperature 37°C and 25%RH, chilled water in/out temperature 10°C/15°C;
- FS007 electrode humidifier as default, other model wet-film humidifier as default.
- Outdoor unit operation temperature range is -20°C~45°C, below -20°C, low temperature kit is required, above 45°C, please contact Kstar.
- Shenzhen Kstar Science & Technology Co., Ltd. reserves the right of final interpretation of the data without prior notice if the data in the table is changed due to technical progress of the product.



◎ Flexibility and compatibility of space

- Compatible with different cabinet, rack-mounted installation
- Occupy less space in cabinet

◎ Accurate airflow

- Unique airflow distribution, it forms cold aisle at front
- "V" shape evaporator have large surface for air, low air resistance, and it makes cooling more high-efficient

◎ Accurate air volume control

- Standare stepless regulation EC fan, optimal airflow distribution, power saving fan

◎ High efficient dynamic output

- DC inverter compressor, it can be adjusted according to the thermal load in real time
- High efficient EC fan, it can adjust the air volume according to the thermal load in real time
- High return air temperature design, high sensible cooling and high power efficiency
- Stepless regulation outdoor unit, smooth running, power-consumption, low noise, high reliability
- Professional low load dehumidification design, it can control the humidity and temperature in the cabinet when the thermal load is very low
- Standard configuration of electronic expansion valve with strong adaptability, allows better energy saving effect in winter

◎ Environmental friendly

- Environmental friendly R410A refrigerant

◎ Technical Parameters

▼DX Unit (Air-cooled Type)

IS***FA	Unit	003		007		012	
Configuration	-	Constant temperature	Constant temperature and humidity	Constant temperature	Constant temperature and humidity	Constant temperature	Constant temperature and humidity
Total cooling capacity ¹⁾	kW	3.5	3.5	7.0	7.0	12.5	12.5
Sensible capacity ¹⁾	kW	3.5	3.5	7.0	7.0	12.5	12.5
Air volume	m ³ /h	700	700	1350	1350	2300	2300
Heating capacity	kW	1.0	1.0	2.5	2.5	5.0	5.0
Humidifying capacity	kg/h	-	0.5	-	0.6	-	1
Number of compressor	PCS	1	1	1	1	1	1
Type of compressor	/	DC inverter	DC inverter	DC inverter	DC inverter	DC inverter	DC inverter
Voltage	V	220	220	220	220	220	220
Frequency	Hz	50	50	50	50	50	50
Phase	P	1	1	1	1	1	1
Full load current	A	17.2	17.4	28.2	28.6	50.2	50.8
Unit weight	kg	27	30	36	39	55	58
Unit width	mm	440	440	440	440	440	440
Unit depth	mm	800	800	800	800	800	800
Unit height	mm	222	222	310	310	444	444
	U	5	5	7	7	10	10

▼Supporting Outdoor unit

KCS***	Unit	005	010	018
Unit weight	kg	38	48	60
Unit width	mm	898	935	981
Unit depth	mm	340	422	440
Unit height	mm	606	807	1256

Notes:

1) Data above is based on indoor return air temperature 37°C and 25%RH, outdoor ambient temperature 35°C.

Refrigerant Pump Assisted Free Cooling Energy-saving Series Precision Air Conditioner



Data Center Energy-Saving High-efficiency Precision Cooling Solution

Refrigerant Pump Assisted Free Cooling Energy-saving series precision air conditioner provides you with perfect solution.

KSTAR Refrigerant Pump Assisted Free Cooling air conditioner is an efficient and energy saving air conditioner developed by KSTAR, it can fully use of natural cold source to reduce the energy consumption of the unit. Based on the KSTAR standard natural cooling unit, it can achieve the cooling function using the compressor system or the Refrigerant Pump system through the refrigerant cycle, no need to add pipe net system and draw into the fresh air. With the integrated design concept, it has the advantages of easy installation and maintenance, high reliability, high efficiency, energy saving and so on. It can be applied in various types of data centers, communications room and other places.

Composition

Refrigerant Pump Assisted Free Cooling air conditioner is consisted of three parts, including indoor unit, outdoor unit and energy saving module; it has the same installation and using mode as standard air cooling unit, which can also has the advantages of simple installation and maintenance.

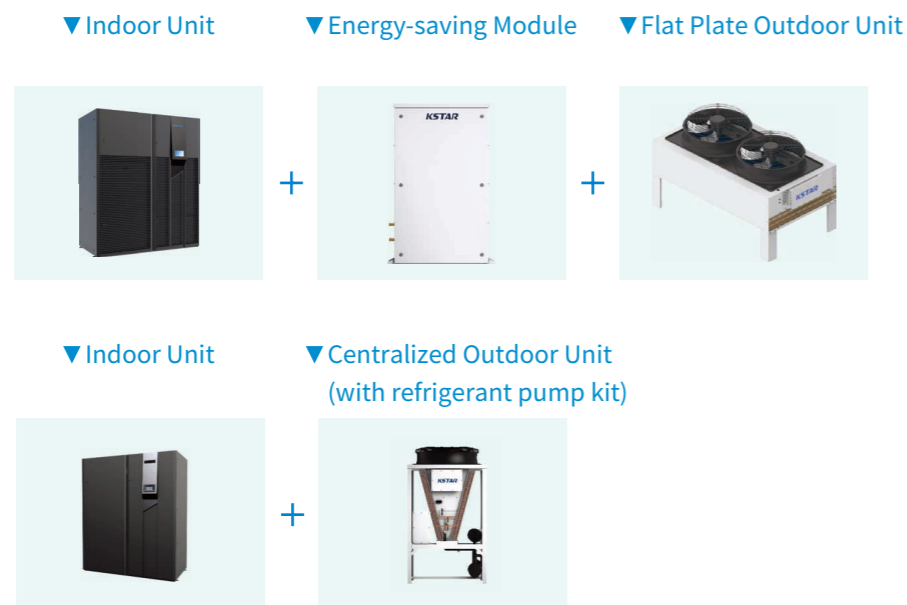

Advantages/Technical Parameters

Operation Features

▼ Compressor Mode

When it has no condition of opening Refrigerant Pump Assisted Free Cooling energy-saving system at high outdoor ambient temperature, the compressor should be started for conventional cooling of compressor.

▼ Refrigerant Pump

When it has condition of opening Refrigerant Pump Assisted Free Cooling energy-saving system at low outdoor ambient temperature, the compressor cooling system should be closed and Refrigerant Pump Assisted Free Cooling energy-saving system should be started for cooling.

▼ Double Engine Mode

When the outdoor ambient temperature is lower but the cooling capacity of refrigerant pump fails to meet the full load of the machine room, the refrigerant pump and compressor should run simultaneously to dig out the maximum efficiency of compressor and realize energy-saving operation.

High-efficiency and Energy Saving

- When outdoor ambient temperature is high, high energy efficiency scroll compressor should be adopted for cooling and realizing high efficiency and energy saving
- When outdoor ambient temperature is low, the compressor should be turned off and Refrigerant Pump Assisted Free Cooling energy-saving system should be adopted for cooling, which greatly reduces the power consumption of the unit
- Double engine mode ensures that the refrigerant pump and compressor work simultaneously, enabling energy-saving operation during transition season
- Single compressor cooling system is equipped with one refrigerant pump free cooling energy-saving module, and double compressor cooling system is equipped with two Refrigerant Pump Assisted Free Cooling energy-saving modules to ensure that all the compressors can be turned off when outdoor ambient temperature is low so as to make full use of natural cooling source and reduce energy consumption
- Fluorine pump natural cooling energy-saving precision air conditioner adopts high-efficiency and energy-saving components the environmental and energy saving characteristics of Kstar's precision air conditioner are also fully inherited
- Intelligent energy-saving controller ensures high-efficient and stable operation of the unit

High Reliability

- It uses high-quality parts and components that have gone through market test for long time
- The advanced and reliable controller ensures that the unit automatically and accurately switches cooling operation mode, and it provides a variety of protection functions to ensure the safe and reliable operation of the unit
- It has intelligent control system with real-time fault diagnosis and alarm prompt

Easy to use

- Highly integrated and modular design, simple installation and easy maintenance are available
- No fresh air is introduced, the airtightness and cleanliness of machine room is maintained, and there is no need of making wall opening
- There is no need of adding water way pipe network system
- Four-sided removable structure provides 100% full frontal maintenance
- Standard RS485 interface is provided for remote monitoring

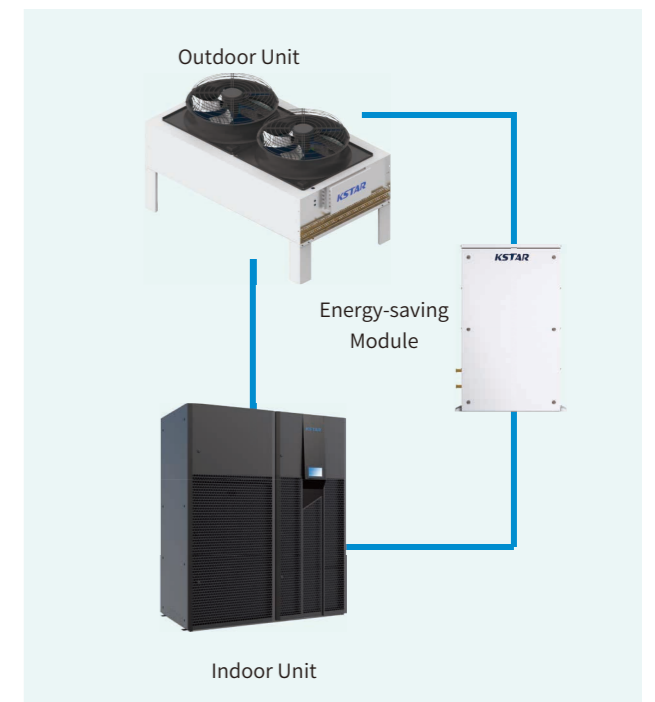

Technical Parameters

MatrixAir™ Refrigerant Pump Assisted Free Cooling Energy-saving Precision Air Conditioner

MT****A	Unit	025	030	035	040 (Single)	045	050 (Single)	040 (Dual)	050 (Dual)	060	070	080	090	100	120
Total cooling capacity ¹⁾	kW	27.0	32.0	36.5	42	47.5	52.5	44.5	53.0	63.0	73.0	84.0	94.5	105.0	123.0
Sensible capacity ¹⁾	kW	27.0	32.0	36.5	42	47.5	52.5	44.5	53.0	63.0	73.0	84.0	94.5	105.0	123.0
Air volume	m ³ /h	8500	10000	11000	12000	13000	13500	12500	13500	18700	19300	21600	24000	26000	26500
Heating capacity	kW	9	9	9	9	9	9	9	9	12	12	12	12	12	12
Compressor quantity	pcs	1	1	1	1	1	1	2	2	2	2	2	2	2	2
Humidifying capacity	kg/h	4.5	4.5	4.5	4.5	4.5	4.5	4.5	4.5	4.5	4.5	9.0	9.0	9.0	9.0
Number of fans	pcs	1	1	1	1	1	1	1	1	2	2	2	2	2	2
Fan type	/	EC fan													
Full load current (Cooling only)	A	23	25	32	36	40	42	37	40	50	50	72	80	84	86
Full load current (Constant temperature and humidity)	A	32	34	42	45	49	51	46	49	64	78	86	94	98	100
Unit Weight	kg	275	350	360	380	400	410	470	490	660	660	680	720	730	740
Unit Width	mm	1128	1128	1128	1128	1128	1128	1128	1128	2228	2228	2228	2228	2228	2228
Unit Depth	mm	995	995	995	995	995	995	995	995	995	995	995	995	995	995
Unit Height	mm	1975	1975	1975	1975	1975	1975	1975	1975	1975	1975	1975	1975	1975	1975
Energy saving module width	mm	606	606	606	606	606	606	606	606	606	606	606	606	606	606
Energy saving module depth	mm	400	400	400	400	400	400	400	400	400	400	400	400	400	400
Energy saving module height	mm	1030	1030	1030	1030	1030	1030	1030	1030	1030	1030	1030	1030	1030	1030

Notes:

- 1.Data above is based on indoor return air temperature 28°C / 40%RH, outdoor ambient temperature -40°C~35°C.
2. Shenzhen Kstar Science & Technology Co., Ltd. reserves the right of final interpretation of the data without prior notice if the data in the table is changed due to technical progress of the product.

FocusAir™ Refrigerant Pump Assisted Free Cooling Energy-saving Precision Air Conditioner

FS***	Unit	025	025	030	030	040	050	060	070
Total cooling capacity ¹⁾	kW	25.5	25.5	30.5	30.5	42.8	52.0	65.0	70.0
Sensible capacity ¹⁾	kW	25.5	25.5	30.5	30.5	42.8	52.0	65.0	70.0
Air volume	m ³ /h	5050	7000	5050	8000	9500	11000	12500	14200
Unit weight	kg	230	265	240	290	290	345	360	375
Unit width	mm	300	600	300	600	600	600	600	600
Unit depth	mm	1100/1200	1100/1200	1100/1200	1100/1200	1100/1200	1100/1200	1100/1200	1100/1200
Unit height	mm	2000/2200	2000/2200	2000/2200	2000/2200	2000/2200	2000/2200	2000/2200	2000/2200
Energy saving module width	mm	606	606	606	606	606	606	606	606
Energy saving module depth	mm	400	400	400	400	400	400	400	400
Energy saving module height	mm	1030	1030	1030	1030	1030	1030	1030	1030

Notes:

- 1.Data above is based on indoor return air temperature 37°C and 25%RH, outdoor ambient temperature -40°C~35°C.
2. Shenzhen Kstar Science & Technology Co., Ltd. reserves the right of final interpretation of the data without prior notice if the data in the table is changed due to technical progress of the product.

KC Series Flat Plate Outdoor Unit

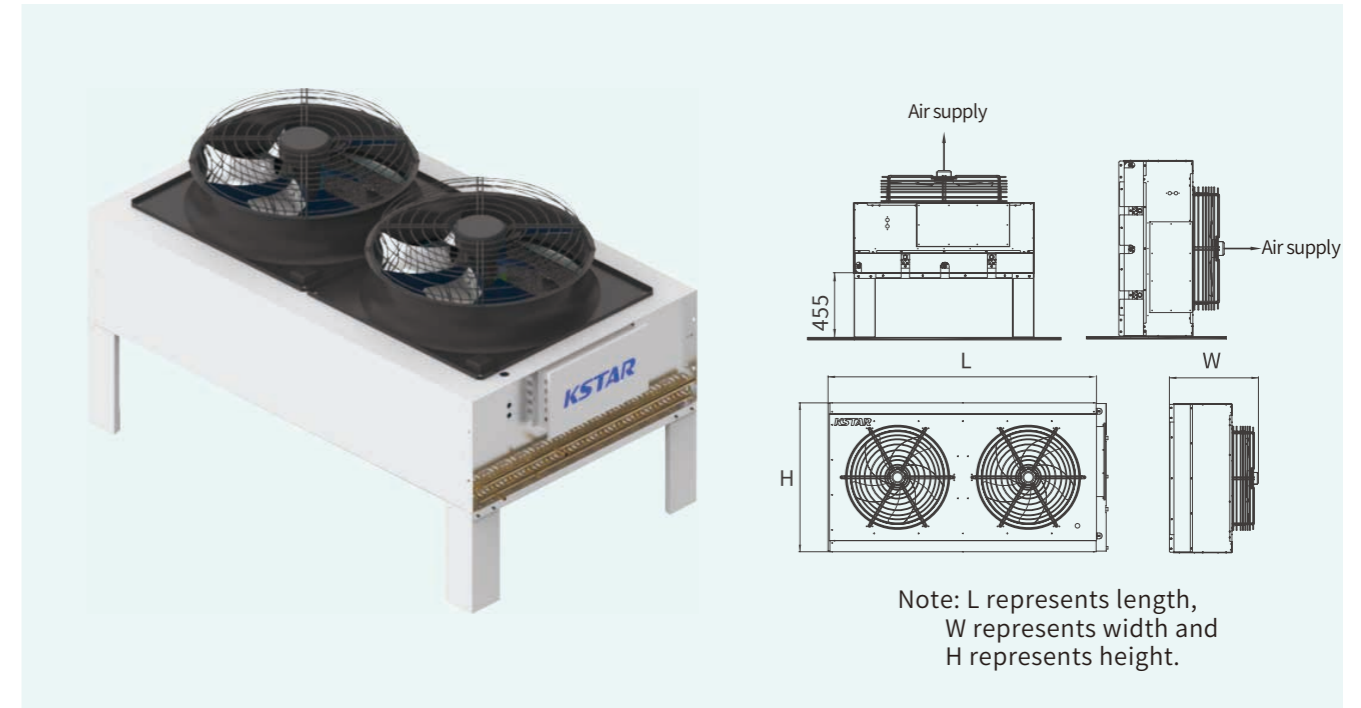

▼Dual Anti-corrosion

- High-quality corrosion-resistant aluminum alloy
- Surface high temperature coating protection

▼Enhanced Heat Transfer

- Enhanced heat transfer internal rifled copper tube
- High-quality corrugated heat exchange fin

▼Intelligent Control System

- Highly sensitive pressure sensor
- Intelligent variable frequency stepless speed regulation controller

▼High-quality Fans

- Industry recognized axial fan is of high quality and maintenance-free.
- Variable frequency speed regulation high-efficiency fan is more energy saving and has lower noise

▼Single/Dual System Design,with Heat Exchange Capacity of 24kw~96kw

- Flexibly matched with indoor unit 1+1 and indoor unit 1+2
- The combined heat exchange capacity can be expanded to 192kW

▼Positive Pressure Seal Maintained among All Fans

▼Standard IP55 Electrical Box Configuration

◎ Technical Parameters

▼ KC Single System Flat Plate Outdoor Unit

KCS**	Unit	024	028	032	036	042	048	054	064	072	084	096
Voltage	V	380	380	380	380	380	380	380	380	380	380	380
Frequency	Hz	50 / 60	50 / 60	50 / 60	50 / 60	50 / 60	50 / 60	50 / 60	50 / 60	50 / 60	50 / 60	50 / 60
Phase	P	3	3	3	3	3	3	3	3	3	3	3
Full-load current	A	2.5	2.5	2.5	2.5	2.5	2.5	2.5	5.0	5.0	5.0	5.0
Weight	kg	115	115	124	134	138	138	152	168	172	245	265
Unit length	mm	1330	1330	1330	1330	1530	1730	1730	1930	2130	2130	2130
Unit width	mm	817	817	817	802	802	802	802	817	817	802	802
Unit height	mm	975	975	1050	1050	1220	1220	1220	1220	1220	1220	1245
Tripod height	mm	455	455	455	455	455	455	455	455	455	455	455

▼ KC Dual System Flat Plate Outdoor Unit

KCD**	Unit	048	054	064	072	084	096
Voltage	V	380	380	380	380	380	380
Frequency	Hz	50 / 60	50 / 60	50 / 60	50 / 60	50 / 60	50 / 60
Phase	P	3	3	3	3	3	3
Full load current	A	2.5	2.5	5.0	5.0	5.0	5.0
Weight	kg	138	152	168	172	245	265
Unit length	mm	1730	1730	1930	2130	2130	2130
Unit width	mm	802	802	817	817	802	802
Unit height	mm	1220	1220	1220	1220	1220	1245
Tripod height	mm	455	455	455	455	455	455

Notes:

- 1.The minimum operating environment temperature of standard unit is -20°C, and the minimum operating environment temperature of low-temperature unit is -40°C;
- 2.Low-noise and customized products can be provided. For more data, please contact Shenzhen Kstar Science & Technology Co., Ltd;
- 3.Shenzhen Kstar Science & Technology Co., Ltd. reserves the right of final interpretation of the data without prior notice if the data in the table is changed due to technical progress of the product.

KC Series Centralized Outdoor Unit



▼ Less footprint

KC series centralized air cooled condenser, under the same heat exchange condition, the unit's ground occupation can be reduced by more than 50%. It is especially suitable for occasions where the outdoor unit needs to be saved or the space for placing outdoor units is insufficient.

▼ More heat transfer area

"V" type heat exchanger design, compared with the traditional "/" type condenser, heat exchange area is larger, heat exchange performance is higher, heat dissipation performance is better.

▼ Modular design

The modules are designed in a unified way and can be quickly assembled on site as required, which is especially suitable for expansion data centers with small reserved outdoor space and new data centers with small available outdoor unit area.

▼ Intelligent control system

- High precision pressure sensor
- Intelligent frequency conversion stepless speed control

▼ High quality fan

- Well-known fans recognized by the industry, high quality and maintenance-free
- High efficiency fan with frequency conversion and speed regulation, large size, more energy saving and lower noise

▼ More options

- Refrigerant Pump energy-saving option
- EC fan option
- Ultra-low temperature operation option
- Ultra mute option
- Spray option

◎ Technical Parameters

▼ KC Single System Centralized Outdoor Unit

KCS**	Unit	032	036	042	048	054	064	072	084	096
Voltage	V	380	380	380	380	380	380	380	380	380
Frequency	Hz	50/60	50/60	50/60	50/60	50/60	50/60	50/60	50/60	50/60
Number of phase	p	3	3	3	3	3	3	3	3	3
Unit weight ¹⁾	kg	168	168	176	184	192	226	226	234	256
Unit weight ²⁾	kg	224	224	232	240	248	282	282	290	312
Unit dimension ¹⁾ (L×W×H)mm		1125×1100×1960								
Unit dimension ²⁾ (L×W×H)mm		1125×1100×1960				1125×1100×2150				

▼ KC Dual System Centralized Outdoor Unit

KCD**	Unit	054	064	072	084	096	108	128	150	170
Voltage	V	380	380	380	380	380	380	380	380	380
Frequency	Hz	50/60	50/60	50/60	50/60	50/60	50/60	50/60	50/60	50/60
Number of phase	p	3	3	3	3	3	3	3	3	3
Unit weight	kg	196	230	230	238	260	370	450	460	466
Unit width	mm	1100	1100	1100	1100	1100	1100	1100	1100	1100
Unit depth	mm	1125	1125	1125	1125	1125	2250	2250	2250	2250
Unit height	mm	1960	1960	1960	1960	1960	1960	1960	1960	1960

Notes:

1. The minimum working environment temperature of standard unit is -20°C, and the minimum working environment temperature of low temperature component is -40°C;
2. Unit weight¹⁾, unit dimension¹⁾ is standard centralized outdoor unit; unit weight²⁾, unit dimension²⁾ is centralized outdoor unit with refrigerant pump;
3. KCD series centralized outdoor unit does not support refrigerant pump built-in;
4. Can provide customized products, if you need more parameters, please contact Shenzhen Kesida Technology Co., LTD.
5. If the parameters in the table are changed without prior notice due to the technical progress of the product, Shenzhen Kesida Technology Co., LTD reserves the right of final interpretation of the parameters.

Precision Air Conditioner Customization Solution



▼ High Temperature Environment Solution

It can support operation at 45°C or higher outdoor ambient temperature.



▼ Low Temperature Environment Solution

It can support operation at -40°C outdoor ambient temperature.



▼ Low Noise Solution

It can support low noise operation in environment with higher noise requirement.



▼ High Altitude Solution

It can support operation in high altitude areas above 1,000m.



▼ Large Air Volume Solution

It can provide users with large air volume solution support.



▼ Long Connecting Pipe/High Drop Solution

It can support the installation environment with equivalent length of above 30m and outside standard drop.



▼ Solution for High External Excess Pressure of the Unit

It can support pressure above the standard external excess pressure of the unit to adapt to on-site requirements.



▼ Cold and Hot Air Channel Containment Solution

It can provide users with application solutions to cold and hot air channel containment.



▼ Accurate Air Supply Solution

It can provide users with accurate air supply solution.

Environmental friendly features of Precision Air Conditioner

Green Earth, Our Beautiful Home

Kstar promotes the healthy development of China's green data center industry with smart technology, joins hands with you and shares the green future with you. As a corporate citizen, Kstar is fully aware of the impact of environment on the sustainable development of enterprises and the future life of human beings. Therefore, Kstar is committed to reducing pollution to the environment by various means, and it promises to provide customers with innovative, high-quality and environmentally friendly products and services, conduct business in an environmentally responsible manner and achieve the sustainable development of our company and society.

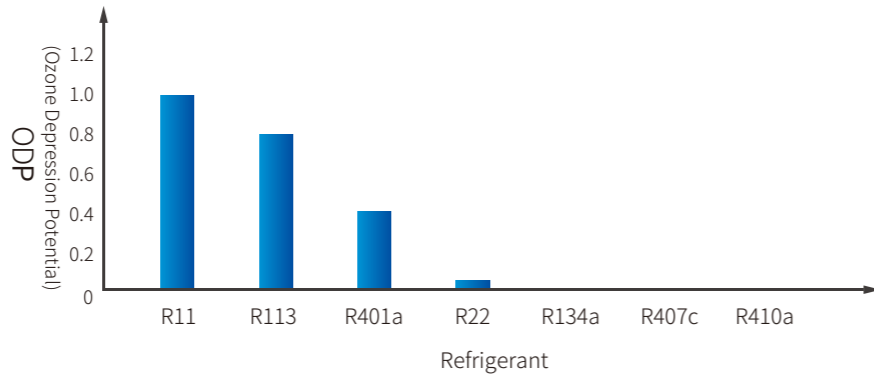
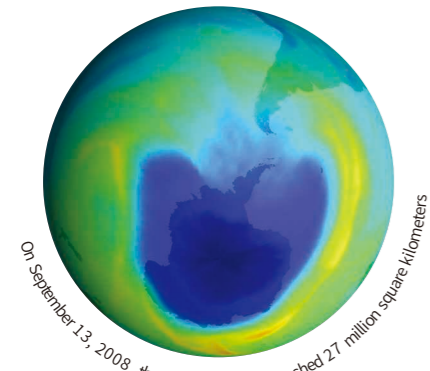

Kstar precision air conditioner uses green R407c, R410a or R134a refrigerants, and ODP is 0. Kstar strives to build green data center and fulfill its environmental protection responsibility.

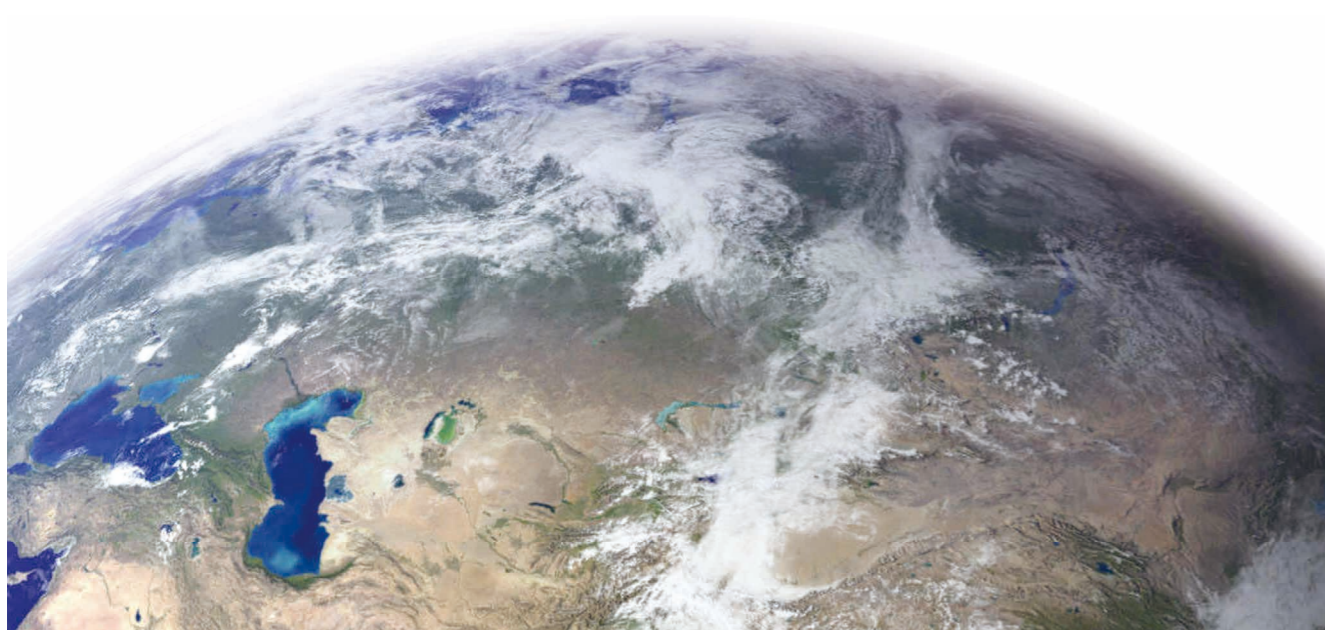

Certifications of Qualifications



Key Hi-Tech Enterprise of National Torch Plan

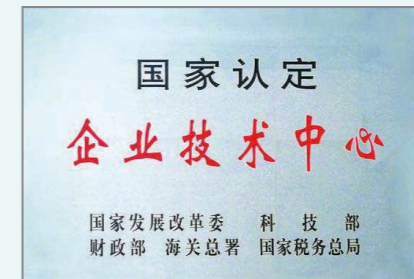

Nationally-Recognized Enterprise Technology Center

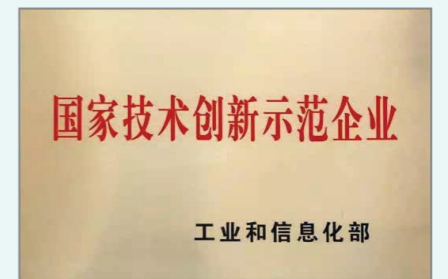

National Technological Innovation Demonstration Enterprise



Post-doctorate Scientific Research Station



Production License for Storage Battery



Production License for Precision Air Conditioner



A-Share Listed Company



ISO9001 Certification

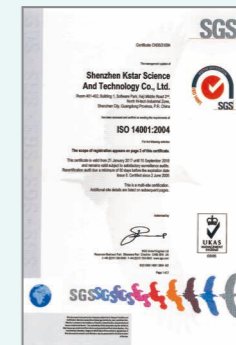

ISO14001 Certification



OHSAS18001 Certification



IECQ QC080000 Hazardous Materials Process Management System Certification

Customer Focused, Quality Oriented



Standing Member Unit of China Power Supply Society



Model Enterprise of Integrity of Guangdong Province



Pollutant Discharge License



Appraisal Certificate for Informatization and Industrialization Integration Management System



Certification of Radio, Film and Television



TLC Certification



Energy-Saving Certification



UL Certification



CE Certification

HEADQUARTERS
 Add: 4/F, No.1 Bldg. Software Park, Keji C. Rd. 2nd, Hi-Tech Industrial Zone, Shenzhen 518057, P.R.China

FACTORIES ADDRESS
 Add: Kstar Industrial Park, Guangming Hi-Tech Industrial Zone, Shenzhen, P.R.China
 Add: Kstar Industrial Park, Fumin Industrial Zone, Guanlan Town, Shenzhen, P.R.China
 Add: Kstar Industrial Park, Zhongkai Hi-Tech Industrial Zone, Huizhou, P.R. China
 Add: CATL-KSTAR, XiaPu Economic Development Zone, FuJian, P.R. China
 Add: Kstar Industrial Park, Yifeng County Industrial Park, Yichun, Jiangxi, P.R. China
 Add: Kstar (Vietnam) Co., Ltd, in Anyang County, Haiphong City, Vietnam

KSTAR
 Website: www.kstar.com

CONTACT
 Tel: +86-755-86169858
 Fax: +86-755-86168482
 E-mail: sales@kstar.com

Kstar reserves the right to change or modify product design, construction, specifications, or materials without prior notice and without incurring any obligation to make such changes and modifications on kstar products previously or subsequently sold. Kstar does not guarantee the items of the accuracy and completeness.

Version number: KSD/C&C 2022-11